

# Accuphase

MOVING COIL PHONO CARTRIDGE

## AC-5

- Pewter housing with manual mirror finish and rhodium and gold plating minimizes vibrations and induction noise
- Microridge stylus shape closely resembles record cutter to ensure wide-range response
- Solid amorphous boron cantilever with high propagation speed
- Samarium cobalt type 30 magnet with excellent thermal characteristics
- "Real sound" type generating coil using 6N-LCOFC wire



Unlike CDs, playback of analog records in high quality requires dedication and an understanding of the various aspects of the process, making the enjoyment of music with this medium a special and truly rewarding experience. The C-27 Phono Equalizer Amplifier from Accuphase has garnered high praise in the audiophile world. We are now taking the next logical step in releasing the AC-5 MC Cartridge. Moving Coil cartridges from Accuphase have a long and distinguished this tradition, history, beginning with the AC-1 in 1979, and followed by the AC-2 and AC-3. The AC-5 picks up this tradition, while incorporating a new design and the finest materials available. It was honed to perfection through extended listening tests and is designed to ensure the ultimate in analog record reproduction.



Phono Equalizer Amplifier C-27

# Moving Coil Phono Cartridge AC-5

## Pewter housing minimizes vibrations and induction noise

Pewter is an alloy of tin (Sn, 91%) with small amounts of antimony (Sb, 7%) and copper (Cu, 2%). It has a beautiful silver-white sheen and features just the right degree of rigidity to ensure minimum self-resonance. For the AC-5, this material has been given a manual mirror finish and rhodium and gold plating.

\* The acoustic velocity of tin (Sn: 2,500 m/s) rivals that of silver (Ag: 2,600 m/s).

## Solid amorphous boron cantilever with high propagation speed transmits stylus movement with ideal fidelity

The cantilever transmits the mechanical vibrations of the stylus at one end to the electricity-generating coil at the other end. It is therefore an important link in producing an accurate electrical signal from the information engraved on the record. One of the requirements is high propagation speed, combined with high rigidity. The AC-5 uses a cantilever with 0.3 mm diameter made of solid amorphous boron. This ideal material achieves a propagation speed of 16,200 m/s, far surpassing beryllium (12,870 m/s) and approaching that of a diamond (18,350 m/s). Since solid amorphous boron has a non-crystalline structure, it is 3 to 4 times stronger than crystal boron which consists of large crystals.

## Microridge stylus ensures long life and wide playback frequency range

The diamond Microridge stylus developed by Namiki Precision Jewel Company provides wide frequency response for playback. This stylus shape, which is also called a line contact stylus (see Figure a large curvature in the depth direction and



● Stylus model magnified 2000 times

1), has a small curvature in the effective tip which contacts the groove. This design significantly improves channel separation, frequency response and other parameters. A special feature of the ridge shape is that it closely resembles the shape of the

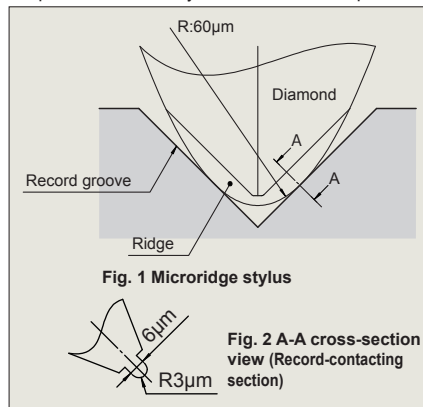

record cutter. Even if the tip is diminished by wear, the curvature radius will always be maintained at 3 micron (see Figure 2), which means long service life.

## "Real sound" type generating coils using 6N-LCOFC wire

In the groove of a phonograph record, in-phase information is engraved in the horizontal direction and out-of-phase information in the vertical direction. The AC-5 therefore employs a symmetrical coil arrangement along the horizontal axis (see Figure 3). This prevents a difference in sonic balance between the signal current for the left and right channels generated by the coils. Imaging and depth are recreated with exactly the same

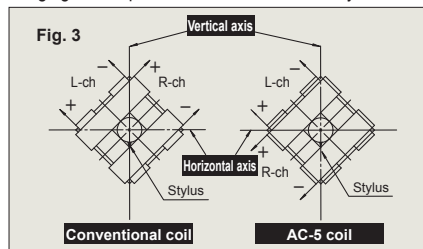

accuracy for both channels, resulting in improved overall reproduction quality. The coils use highly pure oxygen-free 6N-LCOFC wiring with a diameter of 0.03 mm. Despite the low impedance of only 4.5 ohms, a high output rating of 0.24 mV is achieved.

## 8-piece pure damper

The damper serves to support the vibrating parts such as the armature (coil frame) and generator coils, while at the same time controlling the vibrations in the system to achieve the correct damping characteristics. In the AC-5, only pure synthetic rubber without any additives is used for the damper, which is radially divided into eight equally sized sections. This unique construction (see Figure 4) ensures quick response to vibration velocity changes and neutralizes elastic deformation stresses between the channels.

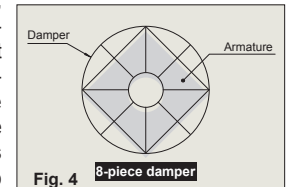

Fig. 4 8-piece damper

## Samarium cobalt type 30 magnet with excellent thermal characteristics

The magnetic material used for the electromagnetic circuitry is samarium cobalt type 30. Its Curie temperature, i.e. the point where the material loses its magnetism, is a very high of 700 to 800 degrees Centigrade. The fact that operation remains stable at high temperatures translates into excellent thermal characteristics also at normal temperatures.

## Wooden case also serves as shell holder



The AC-5 comes in a very handsome black lacquered box made of Japanese cypress wood. As shown in the photo at left, this can also be used to house the cartridge with the head shell attached, by using the supplied shell holder plate.

\* Head shell not supplied. Please purchase a third-party head shell separately.

## Frequency response (L channel)

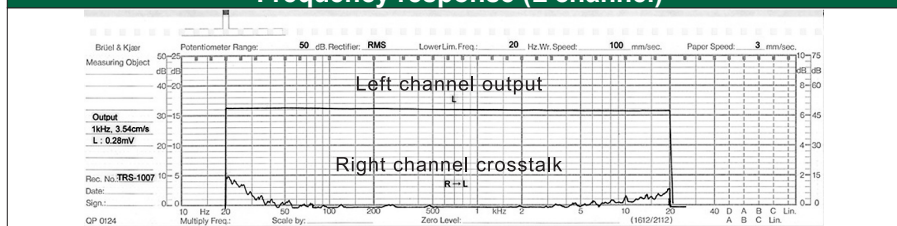

## AC-5 Specifications

- **Cartridge type:** Moving coil
- **Rated output voltage:** 0.24 mV (1 kHz, 5 cm/sec)
- **Impedance:** 4.5 ohms (1 kHz)
- **Frequency response:** 20 Hz to 20 kHz ( $\pm 1$  dB)
- **Channel separation:** 30 dB (1 kHz)
- **Channel balance:** 0.5 dB (1 kHz)
- **Trackability:** 80  $\mu$ m/2.0 g (300 Hz)
- **Generating coil** [Wire material: 0.03 mm dia. 6N-LCOFC  
Layout: Horizontal symmetrical]
- **Magnet:** Samarium cobalt type 30
- **Cantilever:** 0.3 mm dia. Solid amorphous boron
- **Tracking force** [Recommended: 2.0 g  
Range: 1.7 to 2.5 g]
- **Stylus** [Material: Microridge needle diamond 0.1 mm sq. 3  $\mu$ m x 60  $\mu$ m  
Curvature: 3  $\mu$ m x 60  $\mu$ m  
Service life: 2,000 hours (tracking force 2.0 g)]
- **Compliance** [Horizontal: 15 x 10<sup>-6</sup> cm/dyne  
Vertical: 12 x 10<sup>-6</sup> cm/dyne]
- **Output terminals:** 1.25 mm dia. (gold-plated brass)
- **Recommended load impedance** [Amplifier: 100 ohms or higher  
Step-up transformer: 10 ohms or higher]
- **Cartridge weight:** 11.5 g (standard)

● Specifications and design subject to change without notice for improvements.

### Supplied accessories

- Stylus cleaning brush (goat hair)
- Stylus protector (transparent polycarbonate)
- Fastening screws: non-magnetic titanium screws  
M2.6 x 8 mm, 2 pcs.  
M2.6 x 10 mm, 2 pcs.
- Mounting tool: Philips screwdriver

## Dimensions and major structural parts

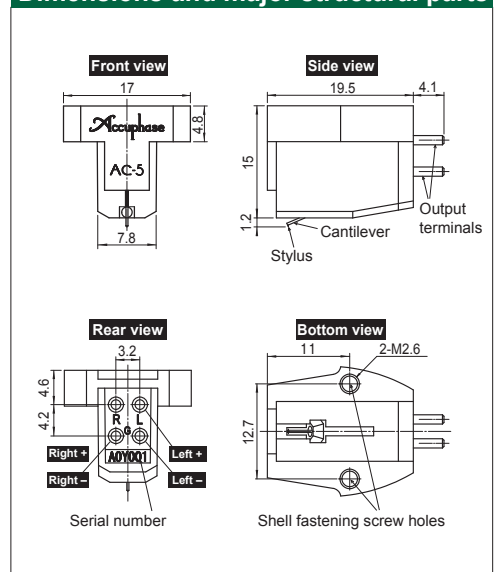

L1005Y PRINTED IN JAPAN 851-0200-00(B1)