

Accuphase

C-270V

PRECISION STEREO PREAMPLIFIER

- Ultimate balanced operation line amplifier
- All-stage class-A push-pull DC servo design
- Complete mono construction with separate transformers for left and right sections
- Four-gang volume control with CP resistor elements
- Logic-controlled signal switching relays for shortest signal paths



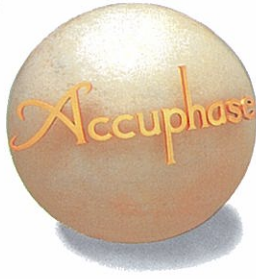

Ultimate Line Amplifier Featuring Flawless Balanced Operation. Unit Amplifiers Powered by Wide-Range, Low-Impedance Dedicated Power Supplies. Mono Construction Throughout, with Separate Left/Right Power Transformers. Four-Gang Volume Control with CP Resistor Elements.

As exemplified by the C-280V, the Accuphase policy for preamplifier development has been to pursue performance and sound quality without any compromise. The C-280V is based on the same strategy. Six years after the introduction of the original C-270, it is a further matured product, where every aspect has been redesigned. The C-270V does not contain a phono equalizer stage, but it features a line amplifier section developed specifically for optimum performance with high-level sources such as CD players.

About 10 years have elapsed since Accuphase introduced the balanced signal transmission principle to the realm of home-use audio components, and many high-end models nowadays include this feature. The line amplifier of the C-270V is based on the ground up on balanced operation, providing a dedicated direct-coupled section for balanced and unbalanced output without the need for transformers. The input stage employs a newly developed FET differential push-pull arrangement that provides high in-phase signal rejection. This type of circuit is ideally suited for balanced amplification. The output section features a symmetrical bridged feedback design for true balanced output. A separate circuit is provided for the unbalanced output jacks. In all, the C-270V is the optimal high-level preamplifier.

Two important tasks of a preamplifier are input source selection and volume adjustment. The C-270V switches sources with hermetically sealed nitrogen gas filled relays operating under logic control and arranged to allow the shortest possible signal paths. This prevents signal degradation and noise intrusion, and also dramatically improves long-term reliability. For the volume control, the same four-gang CP (conductive plastic) resistor as in the C-280V is used. It features an innovative design approach in that the resistor element assembly rotates while the contact brush remains stationary. This drastically reduces the number of metal contact points,

to eliminate any possibility for sound quality deterioration.

Every unit amplifier is housed in a sturdy aluminum enclosure, and the dual-channel mono construction of the 8 mm thick chassis prevents unwanted electrical or mechanical interaction between channels. All signal paths on the PCBs are gold-plated and wiring is kept to a minimum. In each and every detail, the C-270V is built to deliver top-quality audio performance.

Ultimate Balanced Line Amplifier

Accuphase has long been a proponent of balanced signal transmission. The C-270V, like the C-280V, realizes this principle to the fullest. In balanced signal transmission, two identical signals are transmitted simultaneously with inverted phase and combined at the receiving end, thereby canceling out common-mode noise components. Even long cable runs do not affect the quality of the signal, which is why the principle is extensively used in professional applications and broadcast studios etc.

Recently, even in ordinary households, there are many possible sources of electrical and air-borne high-frequency noise which can enter the cables of audio components and cause sound quality degradation. Balanced signal transmission reliably guards against this danger, making it an important requirement for true high fidelity.

The line amplifier of the C-270V was developed specifically to get the full benefit of balanced operation. Fig. 2 shows the principle of this amplifier. In balanced operation (a), three differential amplifiers are active, AMP1 for the input and AMP2 and AMP3 for the output. AMP1 accepts the (+) and (-) signals, amplifies them and supplies them to AMP2 and AMP3. These two amplifiers employ cross-feedback loops, with part of the output of one

amplifier going to the input of the other. This results in a (+) (-) symmetrical signal output with low impedance. In the case of (b), when a component with unbalanced output is connected, it suffices to simply ground one side of the signal at the input and output.

All-Stage Class-A Push-Pull DC Servo Construction

The C-270V possesses separate line amplifiers for unbalanced and balanced output. Fig. 3 shows the circuit diagram of the amplifier for unbalanced signals. The input stage employs a constant-current load cascode bootstrap source follower arrangement that drives a symmetrical balanced differential push-pull emitter follower amplifier with high in-phase signal rejection. The output section is also a symmetrical cascode push-pull emitter follower type. Fig. 4 shows the circuit diagram of the amplifier for balanced signals. The input section is similar to that of the amplifier for unbalanced signals, with an added balanced output amplifier. Like in the C-280V, an inverting and non-inverting amplifier are used, with bridged feedback for balanced operation. Both the inverted and non-inverted output signals are totally isolated from the ground.

All unit amplifiers employ measuring-instrument quality ICs and DC servo circuitry without any capacitors. The result are outstanding temperature characteristics and stable operation with any kind of input signal.

Complete Mono Construction with Separate Transformers for Left and Right Sections

The power supply section also has been redesigned. Two sets of power supply transformers and filtering capacitors preclude any possibility of electrical interaction between the channels. In addition, each unit amplifier has its own wide-range voltage regulator circuitry, to eliminate possible interference between stages.

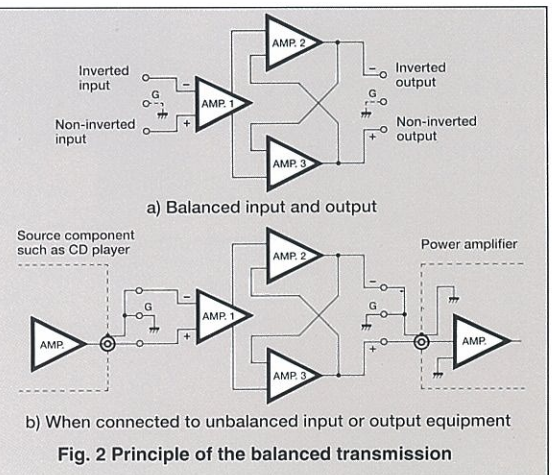
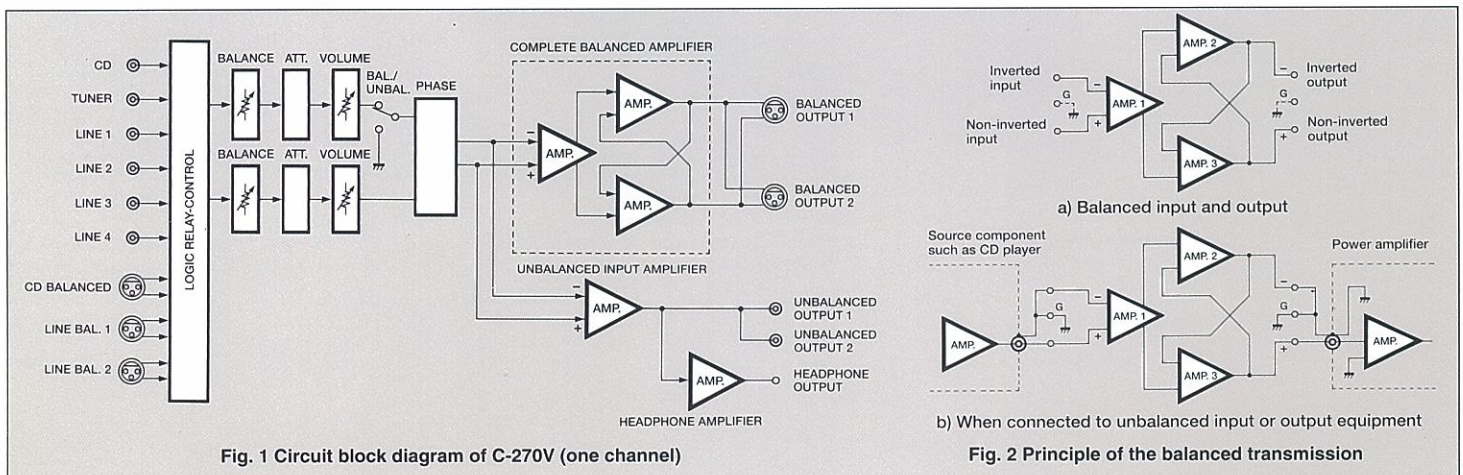



Four-Gang Volume Control with CP (Conductive Plastic) Resistor Elements

The original task of a preamplifier is to serve as signal source selector and to adjust the listening volume. The higher the overall quality of the preamplifier, the more crucial is the influence of the volume control which can have a decisive impact on sound quality. The C-270V therefore uses a CP (conductive plastic) type resistor that is otherwise found only in studio applications. The resistor elements are produced by a printing process followed by a forming stage under high pressure at high temperature. The mirror-like surface finish assures minimum contact resistance and negligible distortion. The contact brush is gold-plated and features a multi-point design. The

outer terminals are integrated with the brush, to eliminate superfluous metal links, thereby reducing distortion that can occur when different metals come into contact. Another innovative aspect of the volume control is the fact that turning the volume knob rotates the resistor element assembly, while the contact brush remains stationary. This drastically reduces the number of internal contact points and eliminates the need for contact grease.

The volume control housing also is specially constructed. The extra-large shaft has a diameter of 8 mm and is made from pure solder material. It is supported by a bearing of extruded aluminum, and each of the four resistor layers is housed in its own extruded-aluminum enclosure, to provide perfect shielding

and ideal VR characteristics. The tracking error is as low as 0.5 dB at the -60 dB position.

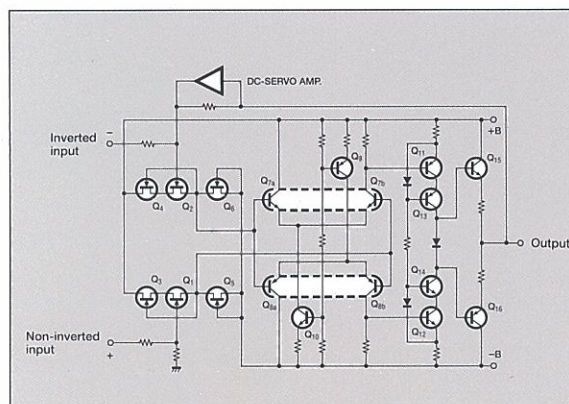

Fig. 3 Unbalanced output line amplifier

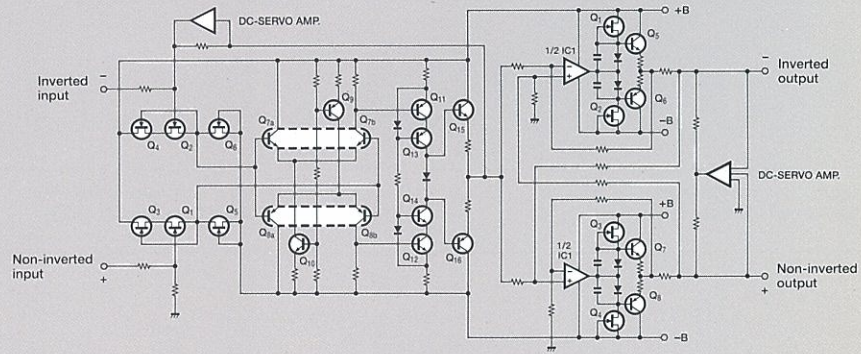
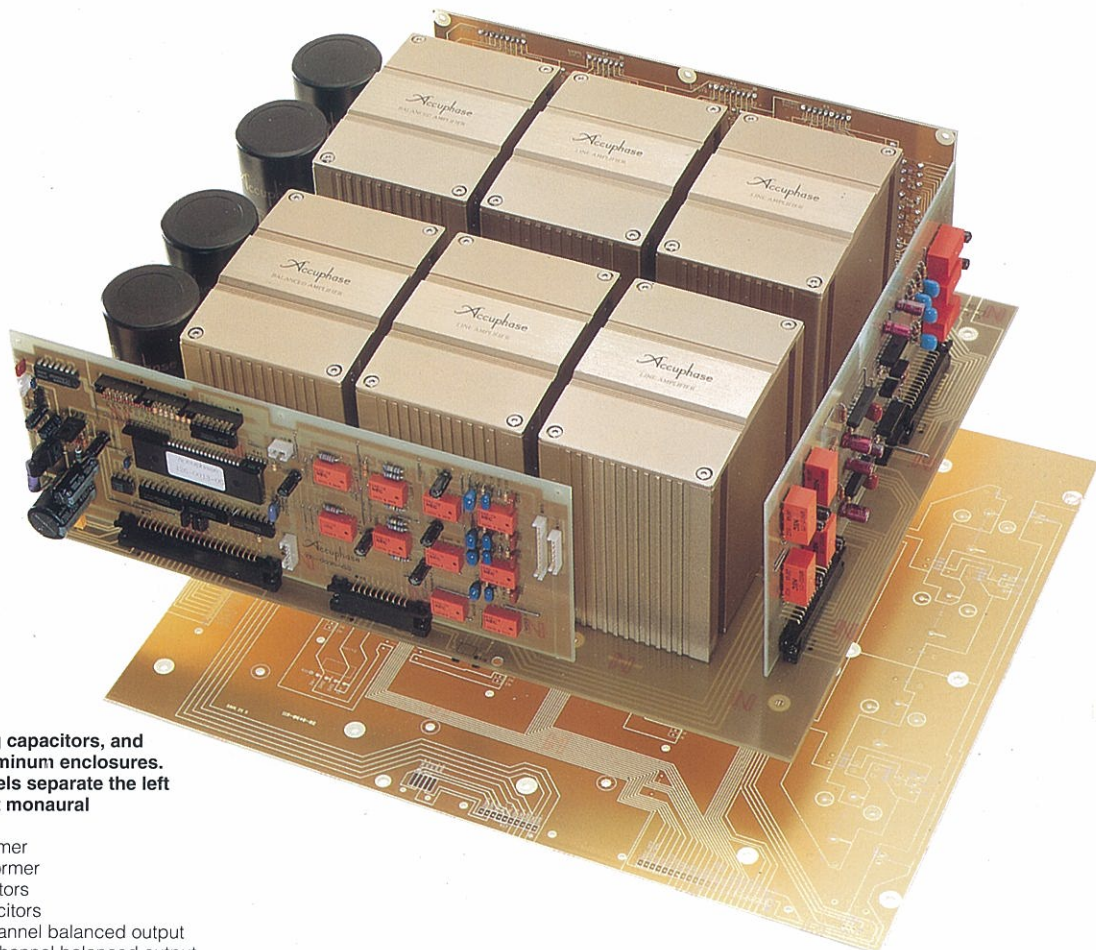

Fig. 4 Balanced output line amplifier



INTERNAL LAYOUT

Two transformers, filtering capacitors, and unit amplifiers in their aluminum enclosures. 8 mm thick aluminum panels separate the left and right sections. Perfect monaural construction throughout.

- 1 Left-channel power transformer
- 2 Right-channel power transformer
- 3 Left-channel filtering capacitors
- 4 Right-channel filtering capacitors
- 5 Line amplifier unit for left-channel balanced output
- 6 Line amplifier unit for right-channel balanced output
- 7 Line amplifier unit for left-channel unbalanced output
- 8 Line amplifier unit for right-channel unbalanced output

Mother PCB with gold-plated copper paths supports the six unit amplifiers, filtering capacitors and peripheral circuitry.

Logic-Controlled Relays for Signal Switching Assure High Sound Quality and Long-Term Reliability

If the signals from the jacks on the rear of the amplifier were routed to the front panel for switching, stray capacitance and other unwanted effects would detract from sound quality. Therefore short signal paths are essential for optimum operation, and switching should occur at points which allow the shortest connection. Protecting the switch contacts from corrosion such as caused by sulphur gases in the atmosphere, air-borne cigarette smoke particles, etc. is also very important. Therefore the C-270V uses special relays placed at strategic locations and governed by a logic control circuit, to provide high reliability and appropriate switching action. The relays which were developed for demanding audio and data transmission applications are filled with nitrogen gas and hermetically sealed. Their contacts are twin crossbar types plated with gold and silver palladium alloy, for minimum contact resistance and outstanding long-term performance.

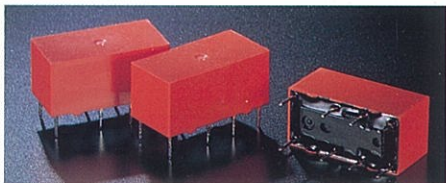

Newly Developed High Quality Exclusive Headphone Amplifier
The C-270V's DC servo, direct coupling head-

phone amplifier can ideally drive headphones with a wide range of impedances.

Unit Amplifiers in Aluminum Enclosures Fastened to 8-mm Hardened Aluminum Chassis

The C-270V contains a total of six unit amplifiers, two for the unbalanced signal section and four for the balanced signal section. The power supply sections for each channel are separate, and each amplifier unit, along with a dedicated local voltage regulator, is housed in a strong enclosure mounted to a large mother PCB. The various units are in turn fastened to

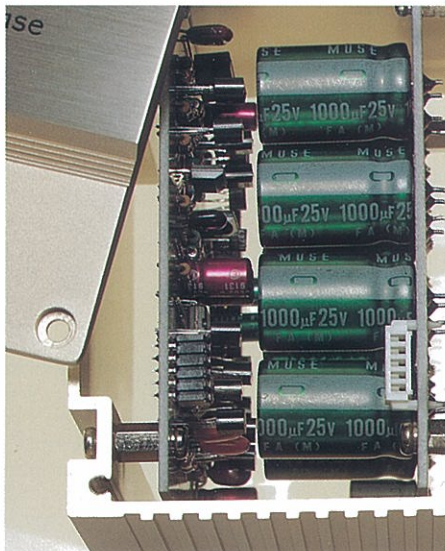

an 8-mm hardened aluminum chassis. Keeping these assemblies separate for each channel guarantees perfect electrical and mechanical isolation as well as superior resistance against vibrations and other unwanted effects.

Eleven Inputs and Six Outputs

To accommodate today's enormous variety of program sources, the C-270V offers a total of eleven inputs including the tape inputs. Three balanced inputs (one for CD and two additional balanced line inputs) and eight unbalanced inputs for RCA-type phono jacks (CD, Tuner, Line x 4, Tape x 2) are provided. The six outputs include two balanced and two unbalanced outputs and two tape outputs. Selector switches determine which output is active, and all outputs can be switched off for headphone listening.

Since the jacks must withstand many plugging and unplugging operations, the surface material must be very hard, and resistance to corrosion is also vital. The C-270V uses special jacks with rhodium plating that is even superior to gold plating. This material has been proven in demanding communication and computer applications. A 1-micron thick plating can withstand more than 100 million plugging actions.



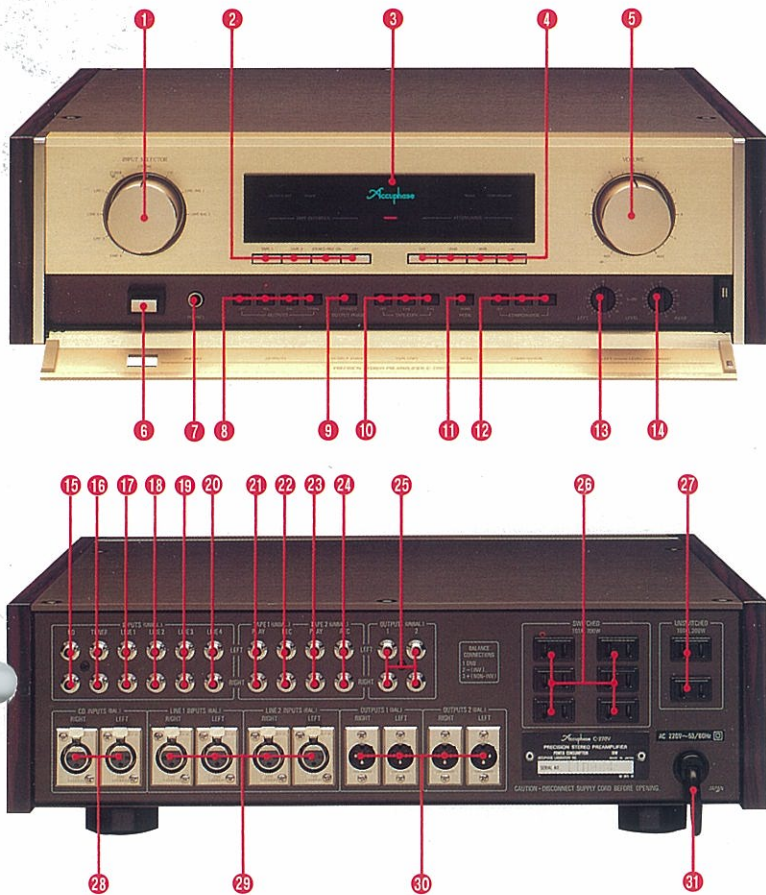

FRONT/REAR PANELS

- 1 Input selector: LINE-4, LINE-3, LINE-2, LINE-1, TUNER, CD-BAL, CD, LINE-BAL 1, LINE-BAL 2
- 2 Tape monitor, recording output on/off switch: TAPE-1, TAPE-2, SOURCE/REC ON/OFF
- 3 Function display LEDs: Muting ON/OFF, OUTPUT OFF, PHASE, MONO, COMPENSATOR, ATTENUATOR, TAPE RECORDER
- 4 Attenuator switch: OFF, -20 dB, -30 dB, -∞
- 5 Volume control
- 6 Power switch
- 7 Headphone jack
- 8 Output selection switch: OFF, ALL, BAL, UNBAL
- 9 Output phase switch: NON-INVERTED/INVERTED
- 10 Tape copy switch: OFF, 1→2, 2→1
- 11 Mode switch: STEREO/MONO
- 12 Compensator switch: OFF, 1, 2
- 13 Left-channel level adjuster
- 14 Right-channel level adjuster
- 15 Unbalanced input CD terminals
- 16 Tuner input terminals
- 17 LINE-1 input terminals
- 18 LINE-2 input terminals
- 19 LINE-3 input terminals
- 20 LINE-4 input terminals
- 21 TAPE-1 tape input terminals
- 22 TAPE-1 recording output terminals
- 23 TAPE-2 tape input terminals
- 24 TAPE-2 recording output terminals
- 25 Unbalanced output terminals (two units)
- 26 Switched AC outlets*
- 27 Unswitched AC outlets*
- 28 Balanced input CD connectors XLR-3-31 or equivalent: (1) Ground, (2) Inverted (-), (3) Non-inverted (+) (Suitable connector: XLR-3-12C or equivalent)
- 29 Balanced input line terminals (two units)
- 30 Balanced output connectors (two units) XLR-3-32 or equivalent: (1) Ground, (2) Inverted (-), (3) Non-inverted (+) (Suitable connector: XLR-3-11C or equivalent)
- 31 AC power cord

* **Remarks:**
 These switched and unswitched AC outlets may not be supplied depending on the safety standards or regulations applicable in the particular country to where the unit is destined.

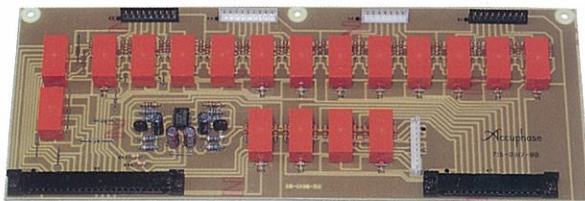

PCB for nitrogen gas filled, hermetically sealed relays operating under logic control, to achieve shortest signal paths and high reliability.

PCB with balanced/unbalanced converter circuitry allows flexible tape recorder output even with balanced input signals.

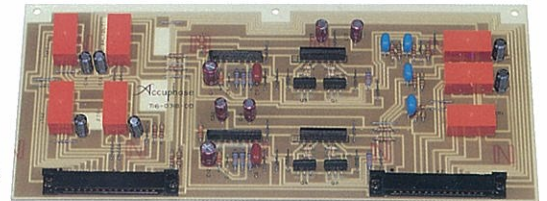

Three-Step Attenuator

When wishing to temporarily lower the volume, such as during a CD track search, or when talking on the telephone, an attenuator function is handy. The C-270V offers a choice of three positions: -20 dB, -30 dB, and -∞ (mute).

Separate Level Controls for Precise Control of Left and Right Output

The C-270V does not have a balance control. Instead, it provides separate attenuators for the left and right channels which allow precise level adjustment to fit the listening position. Between 0 and -6 dB, adjustment is possible in 0.5-dB steps, and down to -14 dB in 1-dB steps. Like those of the volume control, the resistor elements are low-distortion mirror-finish types.

Phase Switching Without Sound Quality Degradation

The overall phase of the entire component can be inverted with a switch. This is performed by changing the (+) (-) assignment of the balanced amplifier, to avoid the sound

quality degradation associated with the circuit load presented by conventional phase inverters.

Other Features

Another important requirement of a preamplifier is easy and versatile tape recorder control. The C-270V has provisions for record/playback connection and monitoring of two tape recorders. A special balanced/unbalanced converter allows use of the tape recorder facilities also during balanced signal operation. Dubbing between the two tape recorders can be performed at the flick of a switch. To allow unattended recordings, the tuner input signal is supplied to the tape recorder outputs also when the C-270V is switched off.

At low listening levels, the human ear becomes less sensitive to the frequency extremes, which can make the music sound thin and hollow. A loudness compensator switch on the C-270V provides the correct compensation, depending on the position of the volume control. This restores a natural listening impression regardless of volume.

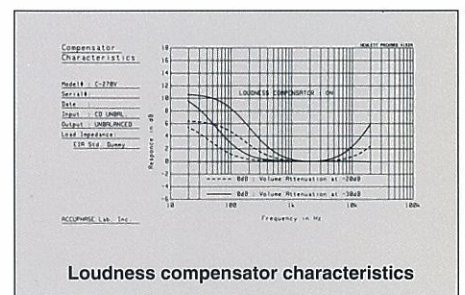

Thick Persimmons Wood Side Panels

In the honored Accuphase tradition, the front panel of the C-270V is finished in brushed gold aluminum. By attaching the side panels of exquisite persimmons wood, the visual appeal of the preamplifier can be even further enhanced, for a harmonious blend with the listening room.

A dedicated line-input preamplifier
designed for CD connoisseurs.
The fruit of 20 years of
Accuphase expertise.



enrich life through technology

GUARANTY SPECIFICATIONS

(Guaranty specifications are measured according to EIA standard RS-490.)

Performance Guaranty

All Accuphase product specifications are guaranteed as stated.

Frequency Characteristics

Balanced input: [CD/LINE]
1.0 to 300,000 Hz +0, -3.0 dB
20 to 20,000 Hz +0, -0.2 dB
Unbalanced input: [CD/TUNER/LINE/TAPE PLAY]
1.0 to 300,000 Hz +0, -3.0 dB
20 to 20,000 Hz +0, -0.2 dB

Total Harmonic Distortion

Less than 0.005% (for all input terminals)

Input Sensitivity and Impedance

Input terminal	Input sensitivity		Input impedance
	Rated output	0.5 V output	
Balanced	252 mV	63 mV	40 kΩ
Unbalanced	252 mV	63 mV	20 kΩ

Rated Output and Impedance

Balanced output: 2.0 V, 50Ω, XLR type connector
Unbalanced output: 2.0 V, 1Ω, RCA phono jack
Tape rec output: 252 mV, 100Ω, RCA phono jack

Headphone jack

Suitable impedance 4 to 600Ω

S/N and Input Converted Noise

Input terminal	Input short-circuited (IHF-A compensated)		EIA S/N
	S/N with rated input	Input converted noise	
Balanced	110 dB	-122 dBV	94 dB
Unbalanced	110 dB	-122 dBV	94 dB

Maximum Output Level (Distortion Ratio 0.005%, 20 to 20,000 Hz)

Balanced output: 7.0 V, XLR type connector
Unbalanced output: 7.0 V, RCA phono jack
Tape rec output: 7.0 V, RCA phono jack

Minimum Load Impedance

Balanced output: 600Ω
Unbalanced output: 1kΩ
Tape rec output: 10kΩ

Gain

Balanced input → Balanced output: 18 dB
Balanced input → Unbalanced output: 18 dB
Balanced input → Rec output: 0 dB
Unbalanced input → Balanced output: 18 dB
Unbalanced input → Unbalanced output: 18 dB
Unbalanced input → Rec output: 0 dB

Loudness Compensator (when the audio volume set to -30 dB)

1: +3 dB (100 Hz)
2: +8 dB (100 Hz), +6 dB (20 kHz)

Attenuator

-20 dB, -30 dB, -∞

Semiconductor Complement

74 transistors, 36 FETs, 25 ICs, 97 diodes

Power Requirements and Power Consumption

100 V, 117 V, 220 V, 240 V AC, 50/60 Hz, 18 watts

Dimensions

475 mm (18-23/32 inches) width,
149 mm (5-7/8 inches) max. height,
375 mm (14-3/4 inches) depth

Weight

22 kg (48.5 lbs.) net
27 kg (59.5 lbs.) in shipping carton

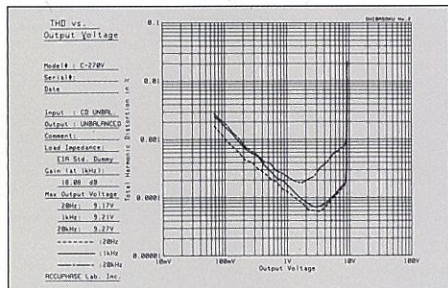

Output power vs. total harmonic distortion
(Unbalanced CD input to unbalanced output)

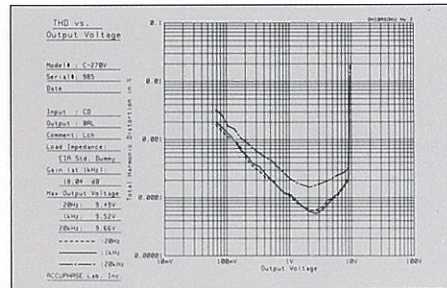

Output power vs. total harmonic distortion
(Balanced CD input to balanced output)

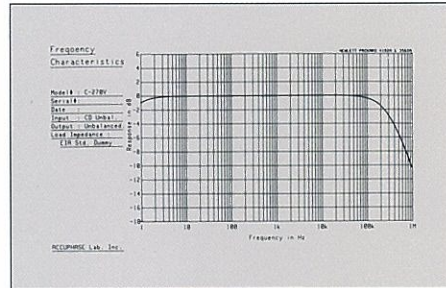

Frequency characteristics



ACCUPHASE LABORATORY INC.

851-0109-00 (GF) PRINTED IN JAPAN