

# Accuphase

MDS COMPACT DISC PLAYER

## DP-510

- High-precision CD drive
- High-quality CD tray and ultra quiet and smooth loading mechanism
- MDS++ D/A converters
- Low-pass "Direct Balanced Filter" with totally separate line and balanced signal paths
- Two sets of transport outputs and digital inputs allow insertion of DG-48 into signal path for sound field correction
- Balanced output phase selector





**Dedicated high-end CD Player designed for optimum sound quality — Highly rigid, high-precision purpose-built CD drive. Processor section with MDS++ type D/A converter featuring six DACs driven in parallel. Fully separate CD transport and processor section, with coaxial and optical transport outputs and digital inputs. Coaxial input supports signals with up to 192 kHz sampling frequency and 24-bit resolution.**

The Compact Disc format with its long history offers an unsurpassed wealth of musical treasures. Many audiophiles want to get the best and most up-to-date reproduction of this format as possible. In response to such demands, Accuphase developed a CD drive in-house and first incorporated it in the high-end dedicated CD player DP-500 which has won enthusiastic praise the world over. The DP-510 is the successor to the DP-500, inheriting its advanced know-how and further refining the capability to bring out all that the Compact Disc format has to offer. Discover a world of musical excellence. Explore the finest nuances of recordings that will sound better than you have ever heard them before.

The CD mechanism in the DP-510 was developed with a simple yet demanding aim: extract the information encoded on the CD one-hundred percent. Using all of its accumulated know-how and expertise of the DP-500 and taking it onto an even higher plane, Accuphase has created an extremely rigid and ultra precise transport mechanism that attains new levels of performance. The processor section employs six strictly selected high-performance delta-sigma devices operating in parallel, forming a further refined MDS++ D/A conversion system. The analog filter which has a significant influence on sound quality is a so-called "Direct Balanced Filter" which provides totally separate analog low-pass filtering for the balanced and line signal paths. This brings out the full musical potential of the CD. The outstanding sound and high performance of the D/A converter section can be accessed also by external equipment. Two sets of optical and coaxial digital inputs accept digital signals from other components, for processing with the highest musical accuracy. The coaxial input can handle audio data up to a sampling frequency of 192 kHz and 24-bit resolution.

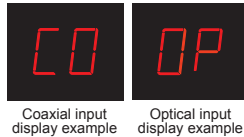

**CD transport section delivers highly pure digital signal**

- **High-precision dedicated CD drive.**
  - ① Highly rigid construction with sturdy chassis absorbs external vibrations.
  - ② "Traverse Mechanism" with floating design and viscous dampers.
  - ③ Integrated design with large bridge cover joined to mechanism base.
  - ④ Low center of gravity and efficient vibration control.
  - ⑤ High-quality CD tray made of extruded aluminum, plus quiet and smooth disc loading mechanism.
- **Fully digital control of CD mechanism.**
- **Balanced drive circuitry for actuator control eliminates interaction with other circuits.**
- **Laser pickup with integrated RF amplifier for drastically reduced noise interference.**
- **Power-on play for automatic playback/Frame indication feature.**
- **Bottom plate with triple sandwich construction (resin plate between two steel plates) completely blocks vibrations.**
- **"High Carbon" cast iron insulator feet with superior damping characteristics further enhance sound quality.**

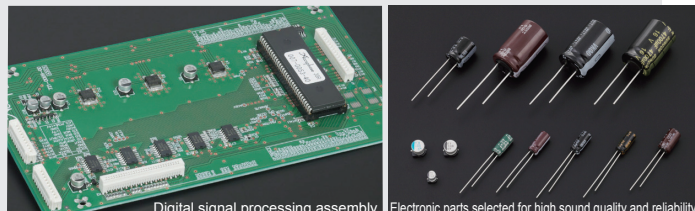
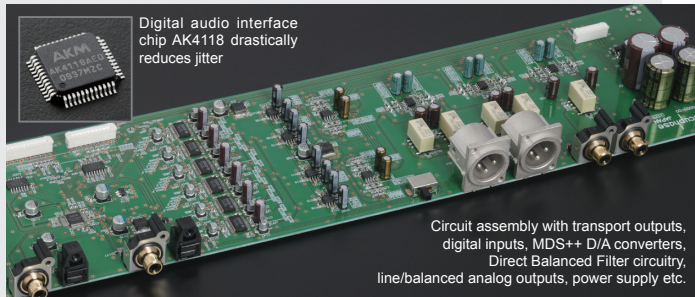
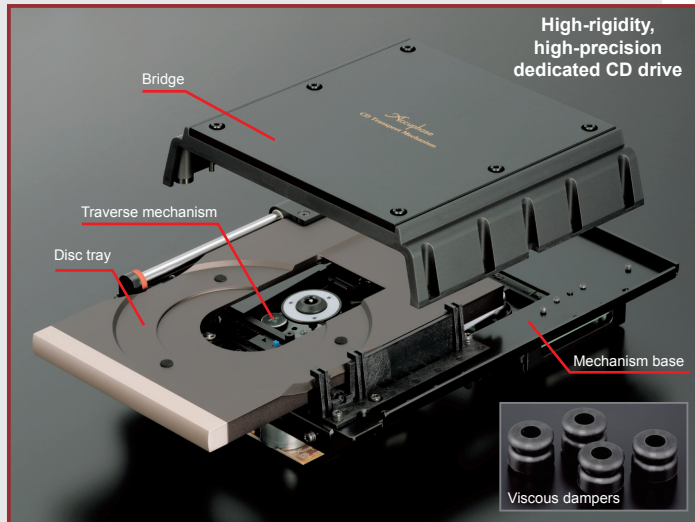
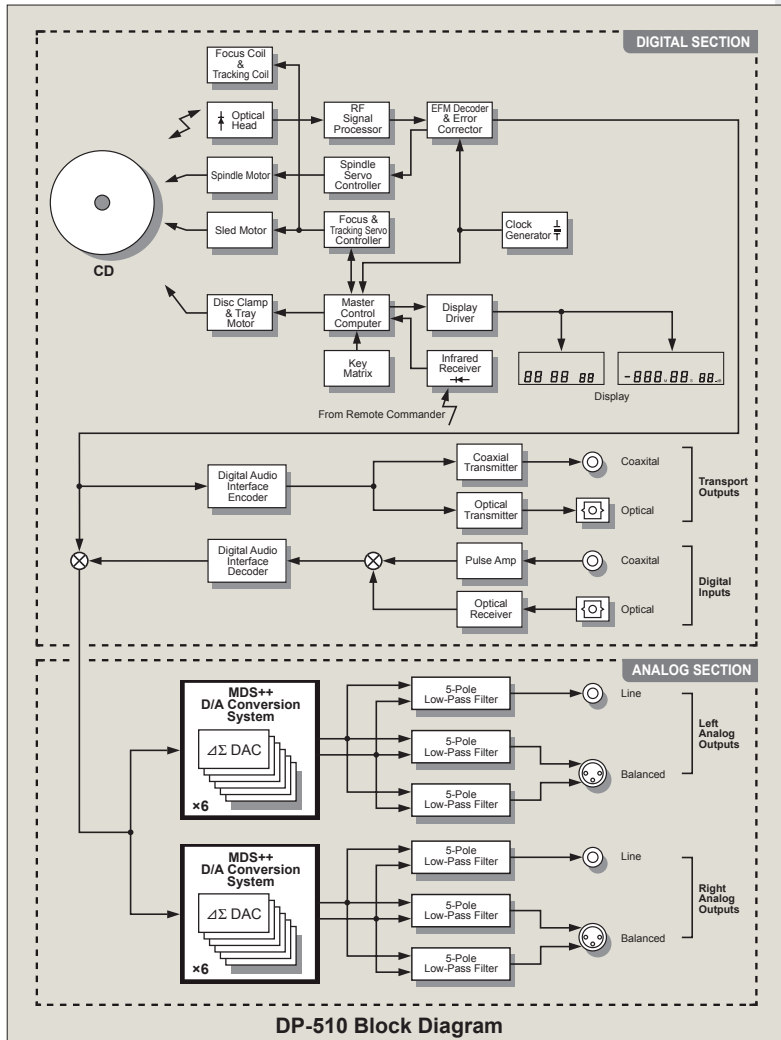





■ Supplied remote commander RC-100 provides access to direct play, repeat play, program play, input source selection, level control, and other functions.

**Further refined MDS++ D/A converter**

MDS (Multiple Delta Sigma) is a revolutionary design which employs several delta sigma type converters in a parallel configuration. The same digital signal is supplied to each converter. In the combined output of these multiple converters, the signal values are added up, but conversion errors cancel each other out, resulting in lower values than by simple addition. The ratio between the signal and conversion errors therefore increases significantly. Converter performance is improved in all relevant aspects, such as accuracy, S/N ratio, dynamic range, linearity, and THD. Furthermore, the improvement afforded by the MDS principle is independent of signal frequency and signal level. This means that noise components are eliminated even at extremely low levels, which is difficult to achieve with conventional designs.

In the DP-510, six delta sigma type PCM1796 converters (made by Texas Instruments) are driven in parallel. Compared to a single converter, this results in an overall performance improvement by a factor of 2.45 ( $= \sqrt{6}$ ).

The MDS++ also features an enhanced current-to-voltage (I/V) converter for processing the D/A converter output current. A combination of current summing and voltage summing is used, resulting in even better stability and top-notch performance. The music emerges from a totally silent background, with breathtaking detail resolution and accurate spatial information.

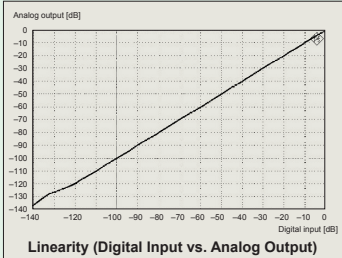
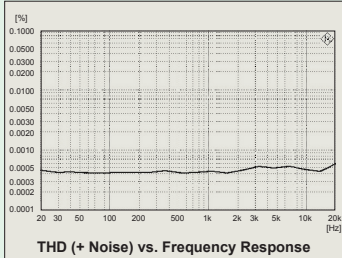
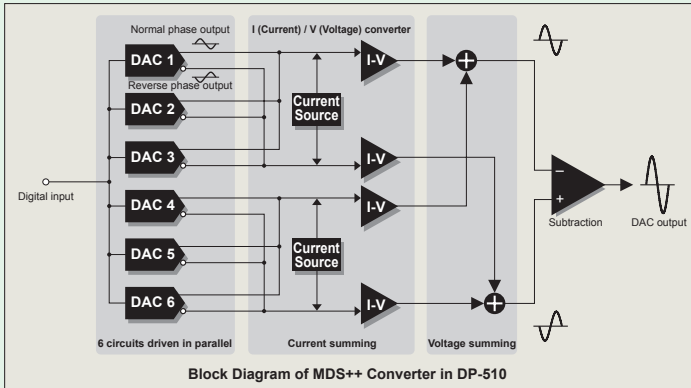
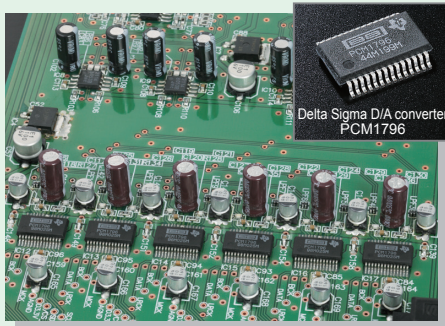



The transport and processor sections of the DP-510 are completely independent of each other. To enable stand-alone use, inputs (coaxial and optical) are provided for supplying the digital signal from other components. The outstanding D/A converter performance of the DP-510 can be harnessed to extract the musical information contained in such digital signals with the utmost fidelity. The coaxial input even accepts S/PDIF data with a sampling frequency of up to 192 kHz and 24-bit resolution.

### Playback example with external digital component

A high-quality musical source downloaded to an external digital component or a computer can be supplied to the DP-510 via the S/PDIF output, for reproduction with outstanding sound quality.

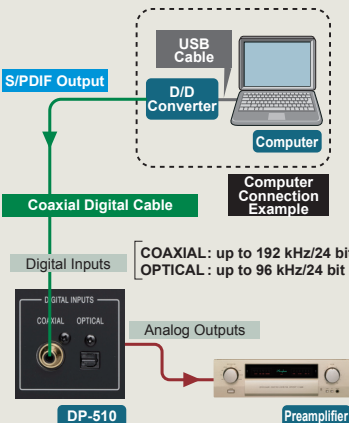

### DG-48 connection example

The DG-48 can be connected between the transport output and the digital input of the DP-510, for sound field processing of the CD transport signal in the digital domain.

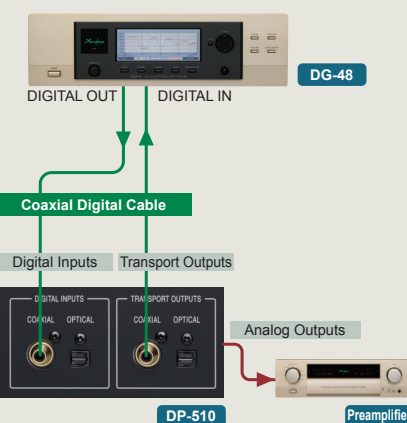

### Direct Balanced Filter with separate balanced/line circuitry

The analog filter circuitry in the DP-510 that removes aliasing noise in the very high frequency range employs 5-pole Butterworth analog filters with extremely flat frequency response in the passband. In order to prevent unwanted interaction, completely separate low-pass filters (LPF) are provided for the balanced and line signal paths.

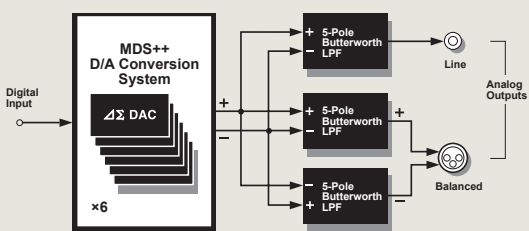

### Phase selector for balanced output

- In the factory default condition, the switch is set to the left side (pin 3 positive).
- If the connected preamplifier or integrated amplifier uses a "pin 2 positive" arrangement, change the setting of the switch.

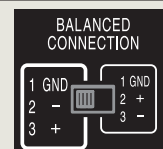

### Front Panel

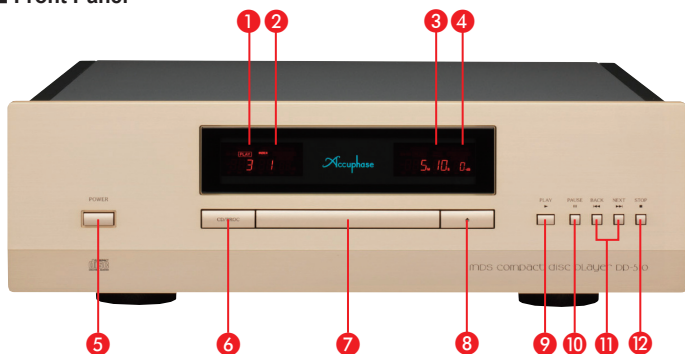

### Rear Panel



- |  |   |
|--|---|
| 1 Play track indicator   | 9 ▶ Play button                                   |
| 2 Total track / index indicator                                      | 10    Pause button                                |
| 3 Time indicator   | 11 ◀◀ BACK / ▶▶ NEXT track search buttons         |
| 4 Output level indicator   | 12 ■ Stop button                                  |
| 5 Power switch   | 13 Digital input connectors (coaxial, optical)    |
| 6 CD transport / processor selector button<br>CD / COAXIAL / OPTICAL | 14 Transport output connectors (coaxial, optical) |
| 7 Disc tray  | 15 Balanced output phase selector switch          |
| 8 ▲ Disc tray open / close button                                    | 16 Balanced output connectors (analog)            |
|  | 17 Line output connectors (analog)                |
|  | 18 AC power connector★                            |

### Remarks

- ★ This product is available in versions for 120/230 V AC. Make sure that the voltage shown on the rear panel matches the AC line voltage in your area.
- ★ The shape of the AC inlet and plug of the supplied power cord depends on the voltage rating and destination country.

- Supplied accessory:
- AC power cord
  - Audio cable with plugs (1 m)
  - Remote Commander RC-100

### GUARANTEED SPECIFICATIONS

[Guaranteed specifications are measured according to the JEITA standard CP-2402A.]  
[Measurement disc: JEITA CP-2403A]

#### CD Transport

- **Format:** Format: Standard CD format  
Quantization: 16 bits  
Sampling frequency: 44.1 kHz  
Error correction principle: CIRC  
Number of channels: 2  
Revolution speed: 500 – 200 rpm (CLV)  
Scan velocity: 1.2 – 1.4 m/s, constant
- **Data read method** Non-contact optical pickup
- **Laser** GaAlAs (double hetero-junction visible-spectrum semiconductor laser diode)
- **Transport output level** COAXIAL (IEC 60958): 0.5 Vp-p, 75 ohms  
OPTICAL (JEITA CP-1212): Light output –21 to –15 dBm  
Wavelength 660 nm

#### Processor

- **Input format** (IEC 60958/AES-3 compliant)  
Quantization: 16 – 24 bits, linear  
Sampling frequencies:  
COAXIAL : 32 kHz to 192 kHz  
OPTICAL : 32 kHz to 96 kHz
- **Digital input level** COAXIAL (IEC 60958): 0.5 Vp-p, 75 ohms  
OPTICAL (JEITA CP-1212): Light output –27 to –15 dBm
- **Frequency response** 4 to 20,000 Hz ±0.3 dB
- **D/A converter** 24 bits, 6MDS++ type
- **Total harmonic distortion** (20–20,000 Hz, 24-bit input) Max. 0.001%
- **Signal-to-noise ratio** 114 dB or better
- **Dynamic range** 110 dB or better (24-bit input)
- **Channel separation** 110 dB or better
- **Output voltage and impedance** BALANCED: 2.5 V into 50 ohms, balanced XLR type  
LINE: 2.5 V into 50 ohms, RCA-type phono jacks
- **Output level control** 0 to –60 dB in 1-dB steps (digital type)

#### General

- **Power requirements** AC120 V/230 V, 50/60 Hz  
(Voltage as indicated on rear panel)
- **Power consumption** 18 W
- **Max. dimensions** Width 465 mm (18-5/16")  
Height 151 mm (5-15/16")  
Depth 393 mm (15-1/2")
- **Mass** 17.8 kg (39.2 lbs) net  
24.0 kg (52.9 lbs) in shipping carton



ACCUPHASE LABORATORY, INC.

E1010Y PRINTED IN JAPAN 850-0162-00 (B1)