

# Accuphase

INTEGRATED STEREO AMPLIFIER

## E-406V

● Triple parallel push-pull configuration delivers 170 watts/channel of quality power into 8 ohms ● Current feedback principle assures great sound and rock-stable operation ● Logic-controlled relays allow very short signal paths ● Dedicated toroidal transformers for preamplifier and power amplifier power supply ● Balanced inputs ● Supplied remote commander ● Two sets of large speaker terminals



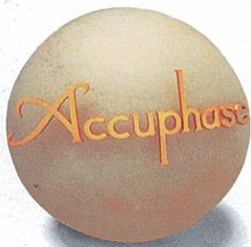

# The new integrated amplifier reference. All signal circuits use current feedback topology for superb sound quality and total operation stability. Ultra-wide-band power transistors in triple parallel push-pull configuration provide 170 watts/channel of quality power into 8 ohms. Option boards allow impeccable reproduction of analog discs.

Based on extensive experience in building superb separate-type amplifiers, Accuphase proudly presents the E-406V, an integrated amplifier destined to become a new reference. Using only the finest of parts, the E-406V delivers sound quality on a truly high level. Dedicated transformers for the preamplifier and power amplifier sections and carefully designed circuit layout ensure total separation of these two blocks. A switch even allows using the preamplifier and power amplifier as independent components.

Accuphase's highly acclaimed current feedback topology virtually eliminates phase shifts in the upper frequency range and assures uniform frequency response which does not change with gain. Phase compensation can be kept at a minimum, and high amounts of negative feedback with their associated disadvantages are no longer required, resulting in excellent transient response, with superb sonic transparency and detail.

The power amplifier output stage employs a triple parallel push-pull configuration, using power transistors designed for high-current audio applications. This improves drive capability especially with critical low-impedance loads. The preamplifier section is designed around a current feedback line amplifier and is driven by a dedicated toroidal power transformer which eliminates any possibility of interference from the power amplifier.

A total of eight input positions including two balanced inputs provide welcome flexibility, including two option slots on the rear of the amplifier for optional input boards. Besides a line-level input board, Accuphase offers an analog disc input board for MM or MC cartridges, allowing reproduction of analog records with outstanding sonic quality.

The tape enthusiast will welcome provisions for two tape recorders, with easy dubbing in both directions. Summing active filter type tone controls and loudness compensation are further advantages. High-performance logic relays are used for signal switching, and a supplied remote commander lets the user operate the unit from any point in the room. The E-406V is an integrated amplifier

with a full complement of features and simply great sound.

## Robust power amplifier section delivers 170 watt per channel into 8 ohms or 220 watts per channel into 4 ohms

Figure 1 shows the circuit diagram of the power amplifier section. The power transistors in the output stage are high-current devices designed specifically for audio applications. They possess optimum frequency response as well as excellent forward-current transfer ratio linearity and switching performance characteristics. By using these transistors in a triple parallel push-pull configuration, the amplifier is able to handle load fluctuations with ease. Operation remains stable at all times, even when driving reactive low-impedance loads. The rated output of 170 watts per channel into 8 ohms or 220 watts per channel into 4 ohms provides more than ample performance margin.

## Current feedback circuit topology in power amplifier and line amplifier sections prevents phase shifts

When the gain of an amplifying circuit increases, frequency response, i.e. the bandwidth that can be handled by the amplifier, becomes narrower. To counter this effect, a commonly employed technique called negative feedback (NFB) routes part of the output signal back to the input. Conventional amplifiers employ voltage NFB, whereby the output voltage is used for the feedback loop. In the E-406V however, the signal current rather than the voltage is used for feedback. Figure 2 shows the operating principle of this circuit. At the sensing point of the feedback loop, the impedance is kept low and current

detection is performed. An impedance-converting amplifier then converts the current into a voltage to be used as the feedback signal. Since the impedance at the current feedback point (current adder in Figure 2) is very low, there is almost no phase shift. Phase compensation can be kept to a minimum, resulting in excellent transient response and superb sonic transparency. Figure 4 shows frequency response for different gain settings of the current feedback amplifier. The graphs demonstrate that response remains uniform over a wide range.

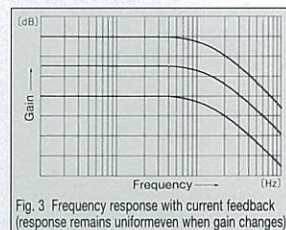

Fig. 3 Frequency response with current feedback (response remains uniform even when gain changes)

## Discrete-type line amplifier for superior sonic purity

The line amplifier whose circuit diagram is shown in Figure 4 is entirely built from discrete parts, to assure opti-

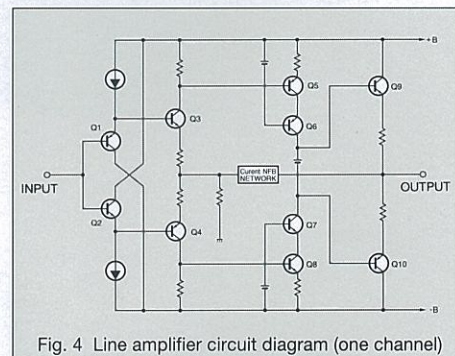

Fig. 4 Line amplifier circuit diagram (one channel)

imum performance. A differential pure complementary push-pull circuit is used, with an emitter follower output stage. Current feedback topology further enhances circuit operation and reduces the need for phase compensation, resulting in effortless, utterly natural and transparent sound.

## Tone controls use summing active filters for pure sound

The tone control circuitry in the E-406V was specially designed with summing active filters such as found in high-quality graphic equalizers. Figure 5 illustrates the operation principle of this circuit. The flat signal is passed straight through, and only when an adjustment is required, the characteristics are created at F1 and F2 and added to the signal, thereby producing the desired change. This design provides efficient control without degrading signal purity.

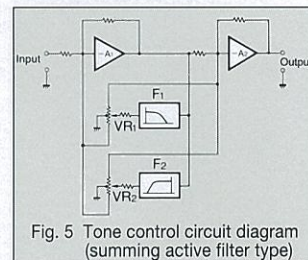

Fig. 5 Tone control circuit diagram (summing active filter type)

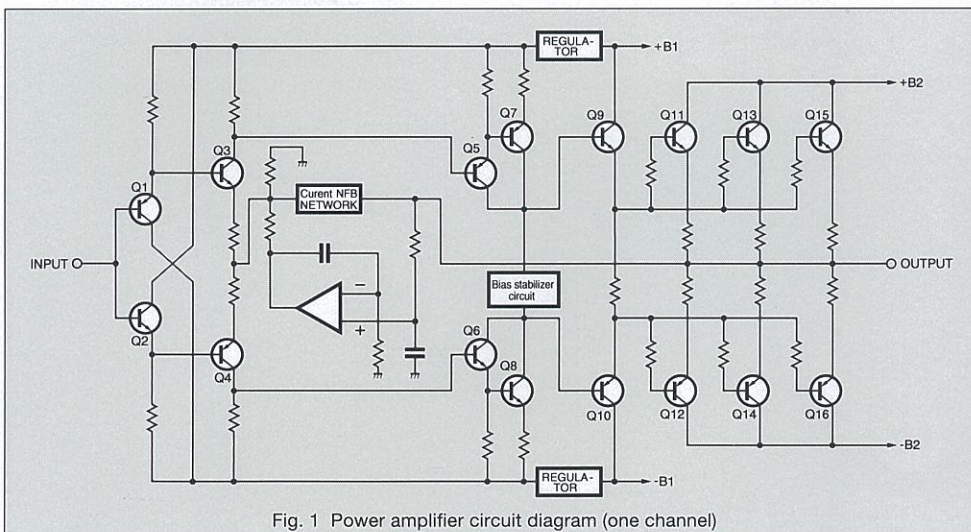
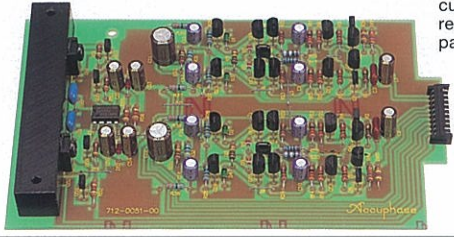

Fig. 1 Power amplifier circuit diagram (one channel)



■ Supplied remote commander RC-20 allows volume adjustment and program source switching.

■ Assembly containing discrete-type current feedback line amplifier, regulated power supply, and other parts.



■ Power amplifier assembly (one channel) with current feedback amplifier and triple parallel push-pull output stage mounted to large heat sink.

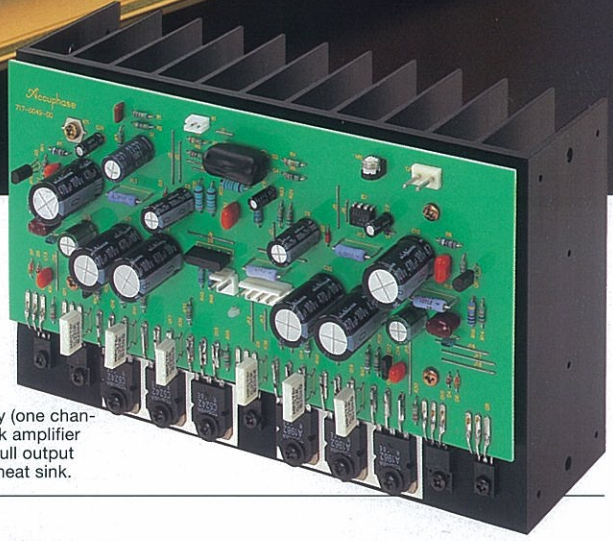

**Highly reliable logic-controlled relays**

Program source switching is performed by logic-controlled relays which are arranged so as to permit the shortest possible signal paths. The hermetically sealed relays are high-quality types developed specifically for demanding communication applications. The contacts are

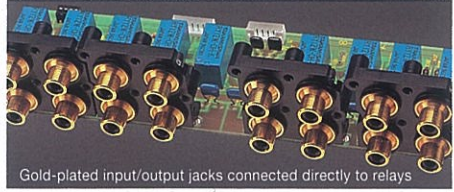

Gold-plated input/output jacks connected directly to relays  
twin crossbar types plated with gold for minimum contact resistance and outstanding long-term reliability.

**Separate power transformers for power amplifier and preamplifier sections**

Dedicated high-efficiency toroidal transformers are used for the power amplifier and preamplifier sections, to eliminate the possibility of mutual interference. Toroidal transformers which use heavy-gauge copper wiring on a ring-shaped core have various advantages, such as very low impedance, small size, and high conversion effi-

ciency. These characteristics make this transformer type ideally suited for audio applications. The E-406V uses transformers with near-circular core caliber. This allows near-circular coil windings with high packing density, resulting in low leakage flux and minimum vibrations. In addition, the smaller ferrite core diameter and copper windings with high specific gravity mean low ferrite losses and low in-rush current.



High-efficiency toroidal transformer for power supply

**Two sets of heavy-duty speaker terminals**

The oversize speaker terminals are made of extruded high-purity brass material which accept also heavy-gauge speaker cable. Two sets of outputs with a speaker selector are provided, and bi-wiring



Large speaker terminals

(supplying the same signal via dual leads to speakers with separate high-frequency and low-frequency inputs) is also possible.

**Large, direct-reading peak power meters**

The large analog power meters have a peak hold function which lets you easily monitor the output level of the rapidly fluctuating music signal. Thanks to logarithmic compression, the meters cover a wide dynamic range.

**Versatile input configuration including balanced connectors**

The input selector of the E-406V controls a total of eight positions, including two positions for optional input boards installed in rear-panel slots. Two of the standard inputs are designed for balanced connections which are impervious to externally induced noise, ensuring signal transmission with optimum sonic purity.

**SEPARATE switch allows independent use of preamplifier and power amplifier sections**

Separate preamplifier outputs and power amplifier inputs controlled by a selector switch allow use of the preamplifier section and the power amplifier section as separate components.

## Option Boards

The rear panel of the E-406V provides two slots in which optional input boards can be installed in a matter of minutes. Two types of boards as shown below are available.

\*Any board can be installed in any empty slot.

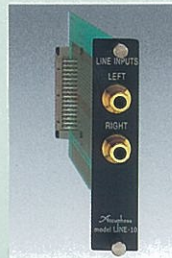

### To add a line input . . .

#### Line Input Board LINE-10

This option board provides an additional set of conventional line inputs which can be used to connect a CD player, tuner, or other component with analog output.



### For reproduction of analog records . . .

#### Analog Disc Input Board AD-10

This board contains a high-performance, high-gain phono equalizer. The board can be used with any type of phono cartridge.

Internal DIP switches control MM/MC operation, MC input impedance, and subsonic filter on/off.

**MM** Gain: 29 dB Input impedance: 47 kilohms  
**MC** Gain: 60 dB Input impedance: 10/30/100 ohms (selectable)

\* Both boards use the AAB (Accuphase Analog Bus) Interface

## FRONT PANEL

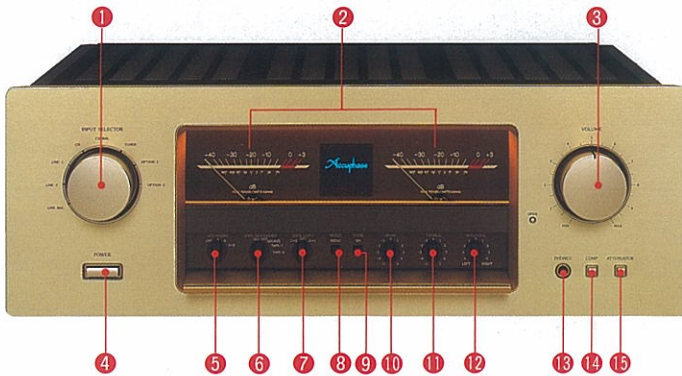

## REAR PANEL



- |                                              |                                                         |
|----------------------------------------------|---------------------------------------------------------|
| 1 Input Selector                             | 16 Loudness Compensator Switch                          |
| 2 Peak Power Meters                          | 17 Attenuator Switch                                    |
| 3 Volume Control                             | 18 Line-level Inputs                                    |
| 4 Power Switch                               | 19 Tape Recorder Input/Output Jacks                     |
| 5 Speaker Selector                           | 20 Speaker Terminals (A/B)                              |
| 6 Monitor and Recording Output On/off Switch | 21 CD/LINE Balanced Inputs                              |
| 7 Tape Copy Selector                         | 22 Preamplifier Output/Power Amplifier Separator Switch |
| 8 Mode Switch                                | 23 Preamplifier Output Jacks                            |
| 9 Tone Control On/off Switch                 | 24 Power Amplifier Input Jacks                          |
| 10 Bass Control                              | 25 AC Inlet (for supplied power cord)*                  |
| 11 Treble Control                            | 26 AC Convenience Outlets (switched)*                   |
| 12 Balance Control                           |                                                         |
| 13 Headphone Jack                            |                                                         |

### Remarks

- \* The shape of the AC inlet, plug of the supplied power cord, and AC outlet depends on the voltage rating and destination country.
- \* These switched AC outlets may not be supplied depending on the safety standards or regulations applicable in the particular country to where the unit is destined.

※ Specifications and design subject to change without notice for improvements.

## GUARANTEED SPECIFICATIONS

※ Guaranteed specifications are measured according to EIA standard RS-490.

- **Continuous Average Output Power :** 220 watts per channel into 4 ohms  
170 watts per channel into 8 ohms (both channels driven, 20 - 20,000 Hz)
- **Total Harmonic Distortion :** 0.02%, with 4 to 16 ohms load (both channels driven, 20 - 20,000 Hz)
- **Intermodulation Distortion :** 0.01%
- **Frequency Response :** MAIN INPUT : 20 - 20,000 Hz +0, -0.2 dB (for rated continuous average output)  
2 - 150,000 Hz +0, -3.0 dB (for 1 watt output)  
HIGH LEVEL INPUT : 20 - 20,000 Hz +0, -0.2 dB (for rated continuous average output)

• **Damping Factor :** 120 (with 8 ohm load, 50 Hz)

• **Input Sensitivity, Input Impedance :**

| Input             | Sensitivity      |                      | Input impedance |
|-------------------|------------------|----------------------|-----------------|
|                   | For rated output | For 1 W output (EIA) |                 |
| HIGH LEVEL INPUTS | 147mV            | 11.2mV               | 20 kilohms      |
| BALANCED INPUTS   | 147mV            | 11.2mV               | 40 kilohms      |
| MAIN INPUTS       | 1.47V            | 112mV                | 20 kilohms      |

• **Output Voltage, Output Impedance :** PRE OUTPUT: 1.47 V, 50 ohms (at rated continuous average output)

• **Gain :** MAIN INPUT → OUTPUT : 28 dB  
HIGH LEVEL INPUT → PRE OUTPUT : 20 dB

• **Tone Controls :** Turnover frequency and adjustment range  
BASS : 300 Hz ± 10 dB (50 Hz)  
TREBLE : 3 kHz ± 10 dB (20 kHz)

• **Loudness Compensation :** +6 dB (100 Hz) (Volume control setting -30 dB)

• **Signal-to-Noise Ratio :**

| Input             | Input shorted, IHF-A weighting | S/N ratio (EIA) |
|-------------------|--------------------------------|-----------------|
| HIGH LEVEL INPUTS | 113dB                          | 82dB            |
| BALANCED INPUTS   | 90dB                           | 82dB            |
| MAIN INPUTS       | 127dB                          | 103dB           |

• **Power Level Meters :** Logarithmic compression, peak reading meters dB and direct watt-reading (8-ohm load) scale

• **Load Impedance :** 4 - 16 ohms

• **Stereo Headphones :** Suitable impedance: 4 - 100 ohms

• **Power Requirements :** 120 V / 230 V (Voltage as indicated on rear panel) AC, 50/60 Hz

• **Power Consumption :** 55 watts idle  
350 watts in accordance with IEC-65

• **Maximum Dimensions :** Width 475 mm (18-11/16")  
Height 180 mm (7-1/16")  
Depth 422 mm (16-5/8")

• **Weight :** 23 kg (50.7 lbs) net  
28 kg (61.7 lbs) in shipping carton

• **Supplied Remote Commander RC-20 :**

Remote control principle : infrared pulse  
Power supply : 3 V DC (IEC R6 batteries x 2)  
Dimensions : 55 (width) x 194 (height) x 18 (depth) mm  
Weight : 100 g (including batteries)

**Accuphase**  
ACCUPHASE LABORATORY INC.

PRINTED IN JAPAN G991.4Y 851-0141-00(AD3)