

Accuphase

MONOPHONIC POWER AMPLIFIER

M-100

- 500W(8-Ohm) realized with Octo-parallel Push-pull Output Stage
- MOS FET Driver Stage
- Built-in Digital Peak Power Display

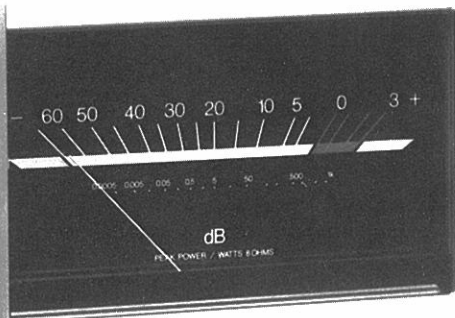

POWER



Accuphase
MONOPHONIC POWER AMPLIFIER
MODEL M-100

LOW FILTER

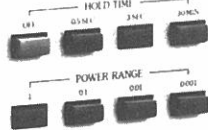
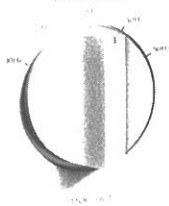

INPUT LEVEL



Anyone engaged in audio engineering will agree that an ideal power amplifier would have to possess the following prerequisites.

(1) Full capability to handle large static and dynamic input signals without distortion. (2) Wide bandwidth characteristics. (3) Low output impedance under open loop conditions (without NFB application). (4) Surplus power supply capability for highest peak current requirements. (5) Full complement output stage. (6) Durable, high stability construction that ensures complete absence of electrical and mechanical resonances.

Prerequisites (3), (4) and (5) are particularly important to achieve ideal speaker driving conditions. For example, when the speaker is driven by the energy from the amplifier its cone vibrations create a counterelectromotive force that flows backward toward the amplifier. This force must be eliminated instantly by the amp's output circuit.

The ideal as measured from the speaker side would be practically a short circuit (very low impedance) condition of the output circuit. Thus power amplifier must not only completely overcome this counterelectromotive force, but it must simultaneously deliver new energy to the speakers.

This calls for the ideal power amplifier to possess a low output impedance under open loop condition, a very heavy-duty output stage and also a power supply with surplus current supplying capability.

The Accuphase Monophonic Power Amplifier M-100 is a product of a design approach which pursued an ideal heavy-duty, high quality sound producing power amplifier. Its array of eight power transistors in a parallel-push-pull (octo-parallel push-pull) output stage and its large capacity Series Regulator type power supply both attest to the seriousness with which we tackled the challenge. The very low impedance characteristics under open loop conditions that was achieved together with the capacity to deliver continuously stable 500 watts of electrical energy at 8 ohms marks another successful forward step in audio technology.

The large power output of the M-100 does not merely mean "big sound" capability. Its also means that a higher grade, quality sound is now available which is the direct result of Accuphase's positive design approach in introducing this outstanding monophonic power amplifier.

The Accuphase M-100 also features, for the first time in the world, a Peak Power Direct Readout System with Digital Display. It permits direct reading of power output peak values which are numerically displayed in watts. It also permits peak value "Hold Time" selection up to 30 minutes for studies of peak power recorded during a choice of three "Hold" periods.

The surplus power and high quality sound of the M-100 will enable everyone to enjoy the unlimited beauty and depth of music to their hearts' content.

HEAVY-DUTY OCTO-PARALLEL PUSH-PULL OUTPUT STAGE

The rated output of the M-100 is 800 watts at 4-ohms and 500 watts at 8-ohms. Accuphase also guarantees its operation at 2-ohms when multiple speakers are connected in parallel to form a 2-ohms load. In this case the rated output is 1,000 watts.

In order to guarantee such a high power output, a total of sixteen bipolar power transistors, each of which has a superior wideband characteristic and a maximum power dissipation (Pc) of 200W rating, form an octo-parallel push-pull output stage. The 16 transistors have a total electrical power capacity of 3.2KW which shows the very large extra margin that supports our output ratings.

Figure 1 shows the amplifying circuit of the M-100. The array of transistors from Q21 to Q36 are the output transistors. Eight each are attached to two separate giant heat sinks located at each end of the M-100 to dissipate heat effectively. Q21 to Q28 are attached to No. 1 Heat Sink, while Q29-Q36 are located on the No. 2 Heat Sink.

Since the two heat sinks are not thermally coupled, a "Bias Balance Circuit" was newly developed to balance the bias current flow to the output transistors and control their respective heat generation. This effectively prevents the possibility of any thermal imbalance between the heat sinks and serves to give full protection to the output transistors.

The Bias-Balance Circuit is centered around the four transistors Q17-Q20 and connects to the common base of the output transistors. Two transistors each are attached to each other's heat sinks to detect their mutual thermal conditions. They function to keep both heat sinks at approximately the same temperature and ensure stable operation by controlling bias current flow to the power transistors.

2 MOS FET DRIVER STAGE IMPROVES HIGH FREQUENCY PERFORMANCE AND ELIMINATES SWITCHING DISTORTION

If a high power amplifier is used in the home at normal listening levels it would be required to supply a mere several watts or so. This means that sound quality at low reproduction levels also becomes a very important factor in designing an ideal power amplifier.

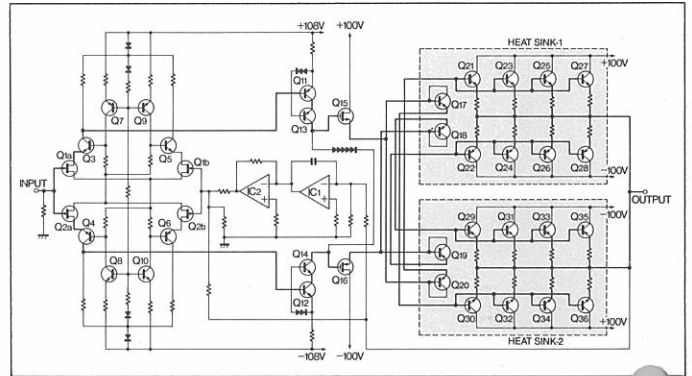

Fig. 1 Diagram of M-100's Amplifier Circuitry

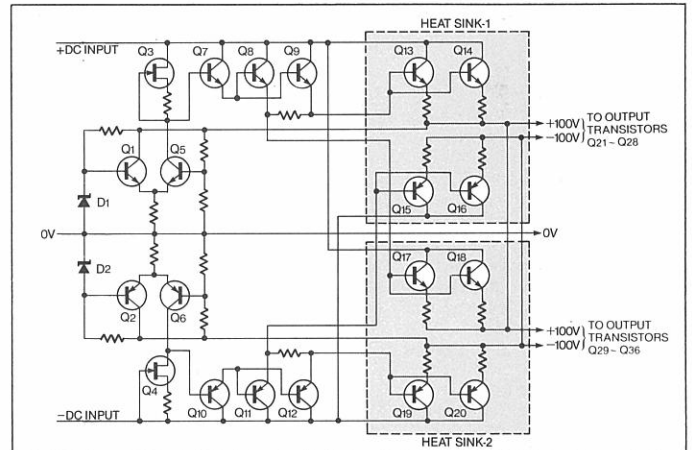

Fig. 2 Diagram of Series Regulator type Power Supply Circuitry

We adopted a sure way to achieve this in the M-100 with the use of power amplification devices MOS FETs (Metal Oxide Semiconductor Field Effect Transistors) in the driver stage, which is the Accuphase's original MOS FET application. This stage requires low output impedance and large current capacity to drive the final output stage, which means a perfect role for MOS FETs which not only can fully meet such requirements, but also improves high frequency performance.

A further advantage of MOS FETs is that their thermal characteristics helps to stabilize bipolar transistor operation which also stabilizes the bias current of the output stage and permits the use of low value emitter stabilizing resistors. Moreover, the total equivalent resistance value of the output stage is further reduced to 1/8 because of the octo-parallel push-pull circuit. This low value of emitter resistance has practically eliminated switching distortion that is normally created when the bias current of the output transistor is cut off.

Q11-Q12 constitute a Cascode push-pull pre-driver stage which features the coexistence of excellent high frequency performance characteristics, together with large amplitude handling capability. The high frequencies are free of Miller effects and the pre-driver stage feeds high quality signals to the MOS FET driver stage.

The M-100 is further designed so that the 16 output transistors are supplied with comparatively large bias current so that they can be worked in pure Class-A operation up to 10 watts output. This further ensures highest quality sound at low reproduction levels.

3 CASCODE BOOTSTRAP, PUSH-PULL DIFFERENTIAL AMPLIFIER INPUT SECTION

The input section employs the traditional Accuphase complementary-symmetry push-pull amplifier in every stage in which all desirable characteristics have been improved to the utmost limits under open loop conditions before NFB application. The input signal is fed to dual type FETs Q1a and Q2a. Q3 and Q4 form a cascode, push-pull amplifier configuration with bootstrap circuit. Advantages which include high gain, improved high frequency performance and no distortion when input impedance is increased, as when the input level control is varied.

The excellent distortionless characteristics of the M-100 are supported by actual measured data (see last page) which shows a complete absence of detrimental IM (Intermodulation distortion) and TIM (Transient Intermodulation distortion).

4 DC SERVO CONTROLLED DIRECT COUPLED INPUT STAGE

The M-100 is provided with a DC Servo Control circuit which effectively eliminates DC current from reaching the output and prevents possible damage to speakers. This permits the elimination of the input capacitor which can cause sound coloration. Use of dual FETs in the push-pull input circuitry prevents DC occurrence, but the Servo Control Circuit gives full protection against possible DC leakage from the preamplifier. It can also neutralize any DC drift that may occur in the M-100 circuitry itself. IC1 and IC2 in Figure 1 are the Servo Control devices. Any presence of DC current in the signal voltage is detected by them and fed back to the inverted input of differential amplifier for complete elimination.

5 SERIES REGULATOR TYPE REGULATED POWER SUPPLY CIRCUIT

The applied voltage to the output stage of power amplifiers tends to fluctuate delicately in accordance with the rapidly changing energy that is supplied to the speakers.

The M-100 has adopted a Series Regulator type Power Supply Circuit shown in Figure 2 to keep this voltage constant.

The input of this power supply receives + and - direct current that has been rectified by a diode and smoothed out by two 22,000 μ F 130V filter capacitors. It has two sets of outputs, one set each at each of the two heat sinks. Each set supplies DC +100V at one output supply point, and DC -100V from another supply point to the four pairs of output transistors attached to the respective heat sinks. The power supplied is regulated and constant, voltage being determined by D1 and D2 and current capacity ensured by eight large power transistors, two each connected in parallel to supply power to each supply point. In other words, four of these power supplying transistors at (+) and (-) each voltage are connected in parallel.

The current capacity of the Series Regulator at 17 amperes per transistor adds up to a total of 68 amperes. This means that the M-100 has twice the current capacity required to meet current requirements of 32A peak current at the rated output of 1,000 watts at 2-ohms. Against the current requirement of 14 amperes for the rated output of 500W at 8 ohms, it has five times the supply capacity. Therefore it can handle with ease any possible momentary maximum current requirements that it will ever be called on to supply.

6 DIRECT READOUT SYSTEM OF PEAK POWER BY DIGITAL DISPLAY

The M-100 is equipped with a direct readout system by digital display of peak power. This system which employs the latest digital technology is being used in a power amplifier for the first time in the world.

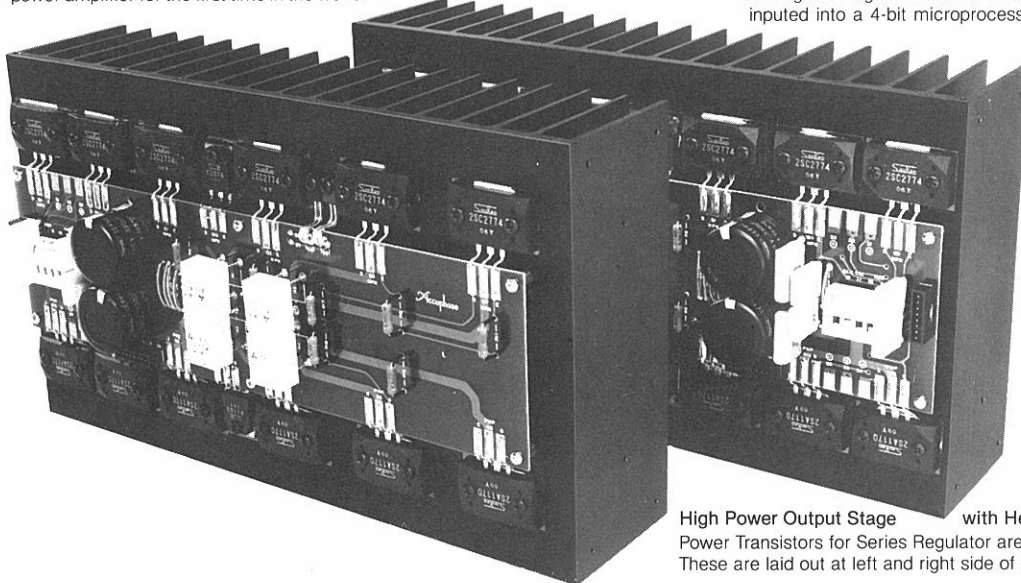

High Power Output Stage with Heat Sink. Power Transistors for Series Regulator are also attached herewith. These are laid out at left and right side of chassis and driven in parallel.

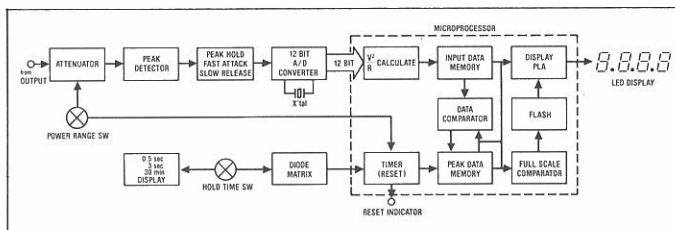
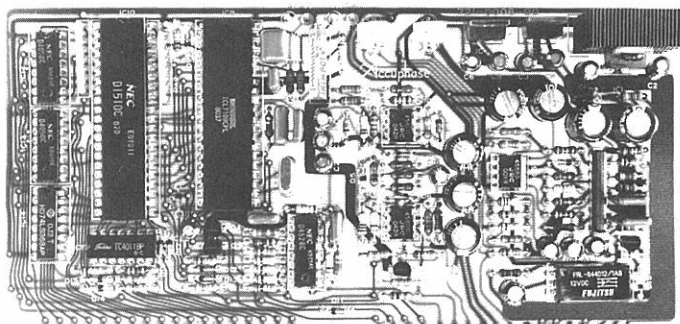
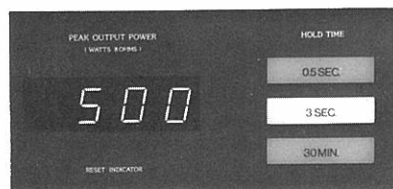

Fig. 3 Block Diagram of Digital Power Display



Digital Display and Meter Drive Circuitry.

The large size IC in the left is newly developed Microprocessor and A/D Converter in the right.



Digital Peak Power Display. Hold time is indicated in the right.

Operation is as shown in the block diagram of Figure 3. The output signal of the M-100 is converted into easy reading magnification ratios by varying the Power Range Switch and is fed to the Peak Detector where the (+) and (-) side waveforms are both transformed to the (+) side.

The next step involves "Holding" the peak value which is fed into a 12-bit analogue to digital converter where it is converted into a digital signal. This signal is inputted into a 4-bit microprocessor which was newly developed by Accuphase to make the peak power digital display possible.

The microprocessor converts the digital signal voltage into terms of power and selects the peak recorded within a certain period for numerical display with LED (Light Emitting Diodes). Other functions of the microprocessor include fixing the "Hold Time", generating the reset signal to start off the new "Hold Time", generating the signal to change the power range and also to generate the over range signal.

The Power Range Switch is varied in four steps, i.e. 1, 0.1, 0.01 and 0.001. This permits direct readout of peak power from 0.001W to 999W with three digits.

"Hold Time" is selectable in three steps, i.e., 0.5 sec., 3 sec and 30 Minutes. The 30-minute range permits learning the peak value reached on one side of a record which enables the examination of the maximum cutting level for that record in comparison with the standard signal of a test record.

Accuphase M-100

MONOPHONIC POWER AMPLIFIER

7 PEAK INDICATING TYPE LOGARITHMIC POWER METER

In addition to the Digital Display, a professional precision meter is provided for observation of power output in terms of decibels, as well as watts. It is convenient because of its large logarithmic scale which enables direct reading of power levels in decibels (dB) from -60dB (0.0005W) to 0dB (100W).

8 1dB STEPPING PRECISION ATTENUATOR

A high quality 24 step genuine attenuator which employs high precision metal film resistors is provided. It enables 1dB step attenuation from 0 to -20dB plus the attenuation of -23dB, -26dB, -30dB and $-\infty$ with fine accuracy within ± 0.1 dB.

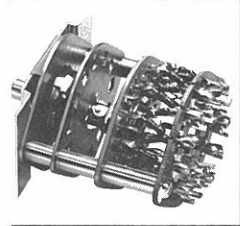

24-step Attenuator consists of precision metal film resistors.

9 LOW FILTER WITH SELECTABLE 10Hz, 17Hz, 30Hz and 50Hz CUT OFF POINTS

A very useful four step Low Filter is provided to cut off low frequency vibrations at 10Hz and 17Hz in the subsonic area and noise at 30Hz and 50Hz. The latter two filters are particularly effective in eliminating background noises during commercial public address system applications of the M-100. All four cut-off filters have attenuation slope characteristics of -12dB/oct.

Cut off frequency selection is variable with front panel switching which activates exclusive relays for each cut off filter that are attached to the printed board. The switch and relay system provides sure action and extra durability.

10 PHASE INVERTING SWITCH

The M-100 has a Phase Inverting Switch with which the phase of the output signal can be inverted contrary to the input signal. It enables using two M-100s for the channel in a bridge connection to double the power output to 1.6KW at 8 ohms.

11 SYNCHRONIZING SIGNAL FOR DIGITAL DISPLAY AND OUTPUT RELAYS

When two or more M-100s are used in plural operation it becomes necessary to synchronize the reset timing of the "Display Hold Time" of the individual units. This can be done by using a synchronizing cable that is provided with the M-100 for connection of the units through the Synchronizing Signal Sockets. The action of the AC Power switches and the timing of the power output relays can also be synchronized by this means.

If your plurally operated M-100s have to be located apart and the 1.5 meter cable is too short, a 5 meter cable can be purchased optionally from your dealer. Refer to it as Timing Cable TC-11.

Besides the ordinary RCA type input connectors, a Cannon XLR type connector is provided. It is very convenient for making safe and sure input connections. It is connected in parallel with the RCA type jacks and its input impedance is 50k ohms unbalanced.

Input Terminals, Phase Inverting Switch and Synchronizing Signal Terminals at rear panel.

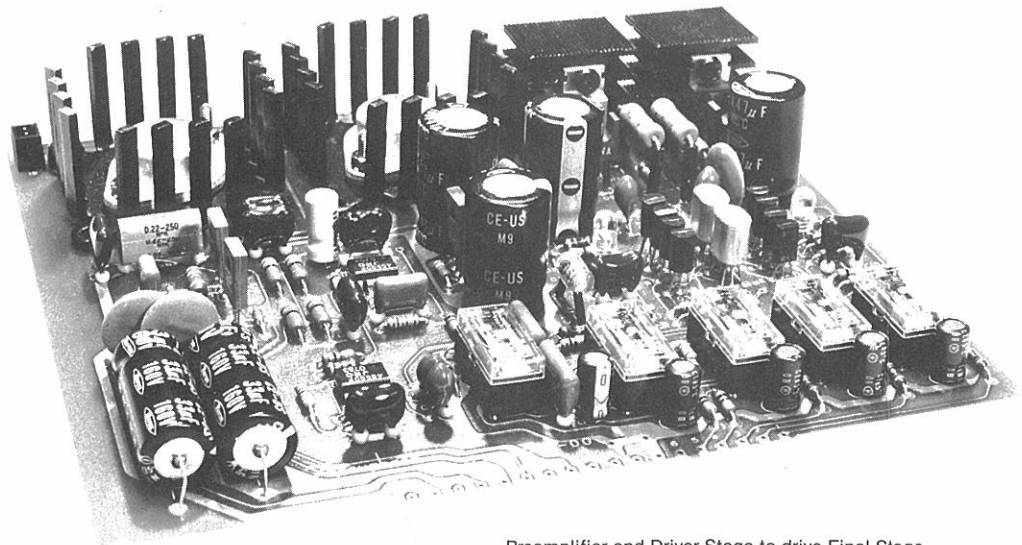

Pre-amplifier and Driver Stage to drive Final Stage. Relays to switch Filter Circuitry is seen in foreground right. MOS FET Driver with Heat Sink is seen in rearward left.

12 PROVISION FOR VENTILATION FAN INSTALLATION

It is not necessary to use forced ventilation for ordinary operation because the M-100 has two very large capacity heat sinks and is well designed for natural air flow and effective heat dissipation.

However, forced ventilation is effective in case the unit is used under extremely poor ventilation conditions or operated continuously for long periods at high power. Therefore space is provided for fan installation. It is recommended that you consult your Accuphase dealer regarding this matter.

Top View of Parts layout

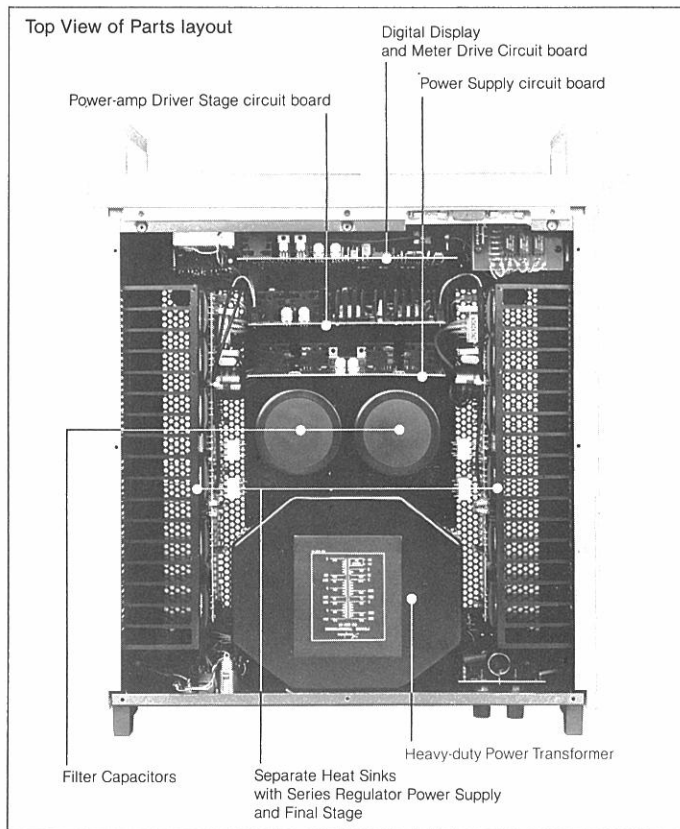

Accuphase M-100

MONOPHONIC POWER AMPLIFIER

GUARANTY SPECIFICATIONS

PERFORMANCE GUARANTY:

All Accuphase product specifications are guaranteed as stated.

CONTINUOUS AVERAGE POWER OUTPUT: (New IHF Standard) From 20Hz to 20,000Hz with no more than 0.01% total harmonic distortion;

800 Watts, min. RMS, at 4 Ohms
500 Watts, min. RMS, at 8 Ohms
250 Watts, min. RMS, at 16 Ohms

TOTAL HARMONIC DISTORTION:

From 20Hz to 20,000Hz at any power output from 1/4 Watt to rated power output;
0.01% max., at 4 Ohms to 16 Ohms.

INTERMODULATION DISTORTION: (New IHF Standard)

Will not exceed 0.003% at rated power output.

FREQUENCY RESPONSE: (New IHF Standard)

20 Hz to 20,000Hz; ± 0 dB for rated output at the maximum level control.
0.5Hz to 400,000Hz; $+0$, -3 dB for 1 Watt output at the maximum level control.
0.5Hz to 140,000Hz; $+0$, -3 dB for 1 Watt output at -6 dB attenuation.

VOLTAGE AMPLIFICATION IN DECIBELS: 27.8dB

INPUT SENSITIVITY AND IMPEDANCE:

2.6V, 50k Ohms, for rated output at the maximum level control.
0.12V, 50k Ohms, for 1 Watt output (New IHF Standard)

OUTPUT LOAD IMPEDANCE: 4 to 16 Ohms

DAMPING FACTOR (New IHF Standard at 50Hz/8-Ohm): 300

INPUT LEVEL ATTENUATION:

24-step type attenuator with 1dB step attenuation from 0dB to -20 dB, and henceforward to -23 dB, -26 dB, -30 dB and infinity. Attenuation error; within ± 0.1 dB

A-WEIGHTED SIGNAL-TO-NOISE RATIO:

130dB below rated output, inputs shorted.
100dB at 1 Watt output (New IHF Standard).

LOW FREQUENCY FILTER:

10Hz, 17Hz, 30Hz and 50Hz cutoff, 12dB/oct.

DIGITAL POWER DISPLAY:

TYPE: Peak power display in wattage at 8-Ohm load.
DISPLAY DIGIT: Three digits by LED digital display.
DYNAMIC DISPLAY RANGE: Digital read-out from 0.001W to 999W depending on the setting of the Power Range Switch.

POWER RANGE 0.001; 0.001W to 0.999W

0.01; 0.01W to 9.99W

0.1; 0.1W to 99.9W

1; 1W to 999W

SAMPLING HOLD TIME: 0.5 SEC, 3 SEC and 30 MIN.

FREQUENCY RESPONSE: 20 to 20,000Hz, $+0$ dB, -0.2 dB.

PULSE RESPONSE TOLERANCE: $+0$ dB, -0.4 dB with a half-wave of 100Hz sine-wave.

POWER LEVEL METER: Logarithmic Scale Peak Level indication of the dynamic range from -60 dB to $+3$ dB, calibrated to read 0dB at 500 Watts into 8 Ohms load.

SEMICONDUCTOR COMPLEMENT: 67 Tr's, 7 FETs, 21 ICs and 75 Di's.

POWER REQUIREMENT: Voltage selection by rewiring for 100V, 117V, 220V and 240V 50/60Hz operation.

POWER CONSUMPTION: 250 Watts at zero signal output.

350 Watts at 50W output into 8 Ohms load.

840 Watts at rated power output into 8 Ohms load.

DIMENSIONS: 480mm (18-15/16 inches) width, 232mm (9-3/16 inches) max. height, 476mm (18-12/16 inches) depth.

WEIGHT: 41.5kg (91.4 lbs) net.

48.0kg (105.7 lbs) in shipping carton.



Rear Panel View

NEW IHF-IM DISTORTION SPECTRUM AND TIM SPECTRUM OF THE M-100

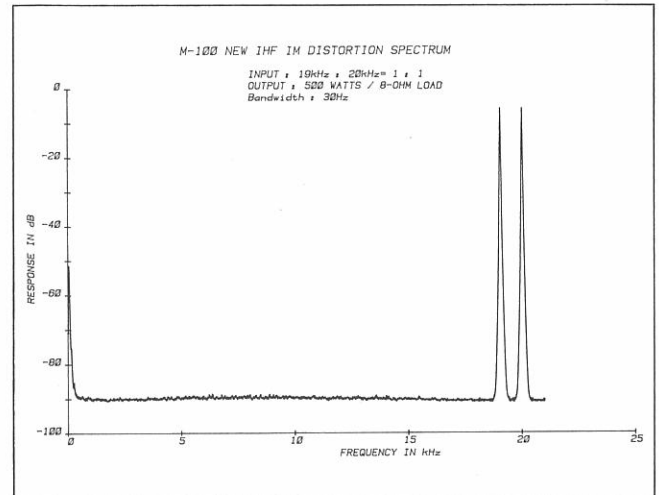

The above data shows the spectrums of intermodulation distortion for the M-100 as measured by the new IHF measurement method. Amplitudes of a 19kHz and 20kHz input signals are shown at the right side. Any intermodulation created by these two signals would appear as spectrum peaks at 1kHz intervals, the frequency difference between the two signals, across the frequency bandwidth. This data shows them to be hardly noticeable, confirming that IM distortion is less than -93 dB (0.0022%).

Another form of IM distortion would appear at 39kHz, the sum of the two input signal frequencies ($19 + 20 = 39$ kHz). Such a distortion, even if it existed, would be inconsequential because it is far beyond the audible range. In the M-100, this form of IM distortion is also less than -93 dB.

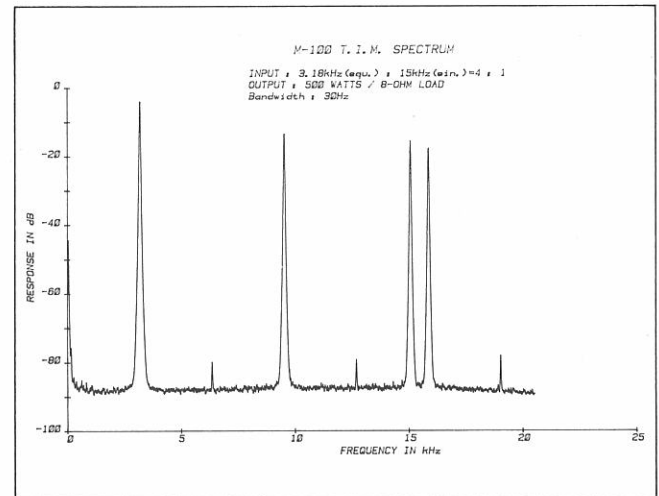

The above data shows the spectrum characteristics of transient intermodulation distortion for the M-100 when two mixed input signals, a 3.18kHz square wave and a 15kHz sine wave, are used. Since harmonics of square waves appear almost infinitely at odd number multiples, for example in this case at 9.54kHz (3rd harmonic) 15.9kHz (5th harmonic), they can create, together with the 15kHz input sine wave, intermodulated spectrums at frequencies where input signals are absent. For example, if the third harmonic of the 3.18kHz square wave (9.54kHz) and the 15kHz input signal intermodulate, a spectrum can appear at the difference of their frequencies or 5.46kHz ($15 - 9.54 = 5.46$ kHz). However, the above data shows no spectrum above -93 dB at that frequency which confirms that TIM distortion is less than 0.0022%. Spectrums appear at frequencies of 6.36kHz, 12.72kHz and 19.08kHz are even number harmonics included in the original square wave signal.

Accuphase M-100

MONOPHONIC POWER AMPLIFIER

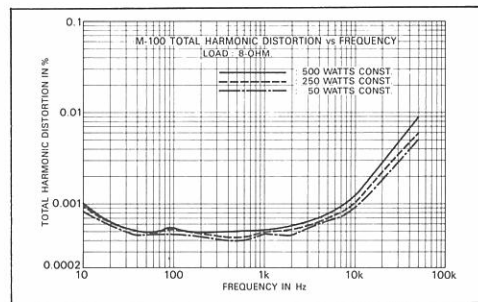
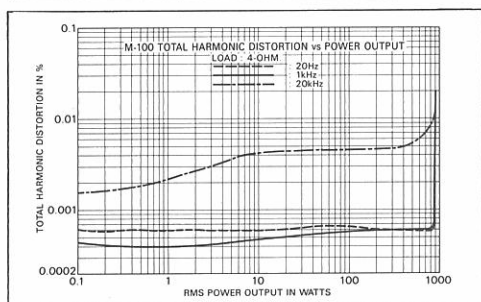
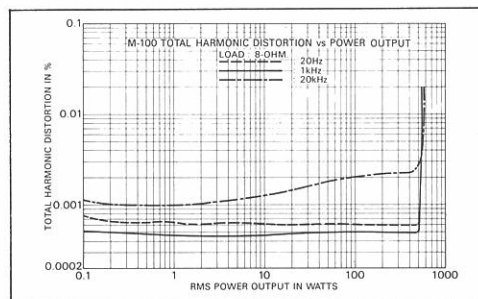
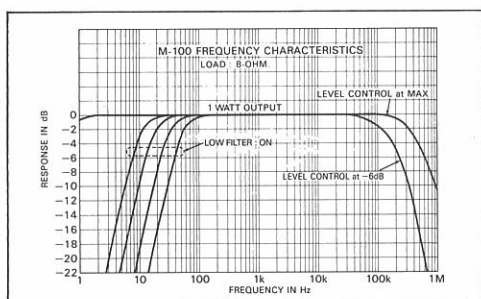
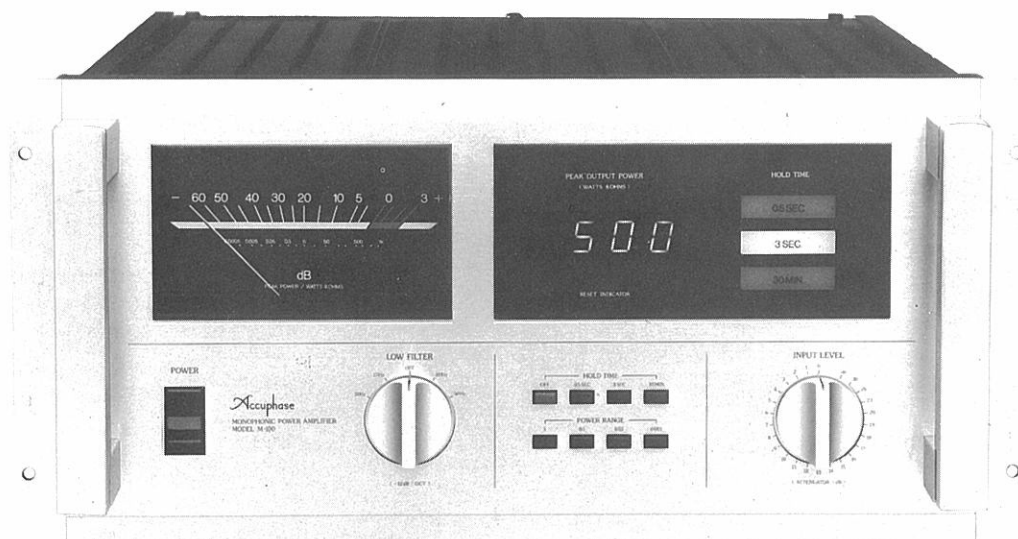

Accuphase
ACCUPHASE LABORATORY INC.