

# Accuphase

FREQUENCY DIVIDING NETWORK

## F-20

- Two-way model with fully balanced input and output circuitry
- Gaussian curve assures optimum phase response
- High-precision GIC filters • Accurate level controls
- Phase selector without sound quality degradation • Three selectable attenuation slopes • Switchable subwoofer mode



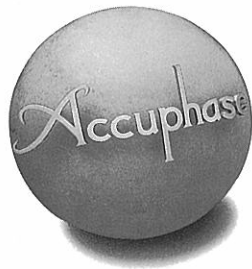

**Scale the Pinnacle of Sound With a Multi-Amplification System. Two-Way Frequency Dividing Network Offers Fully Balanced Input and Output Stages. High-Precision GIC Filters and Gaussian Curve Assure Great Sound and Excellent Phase Characteristics. Choice of Three Attenuation Slopes in Each Frequency Band.**

The F-20 is designed to serve as the heart of a high-quality multi-amplification system. It is a two-way frequency dividing network incorporating sophisticated technology developed for the highly renowned multichannel model F-25. Multi-amplification systems—where each speaker unit has its own dedicated power amplifier—are the pinnacle on the road to audio perfection. The increased complexity of such a system is offset by the dramatic increase in sonic definition and musical accuracy. Another advantage for the serious audiophile is the fact that it is possible to pursue one's own sonic ideals without compromise.

The F-20 reflects the long experience of Accuphase with balanced signal transmission. Another important feature are the GIC filters built with strictly selected high-quality devices. The filters are designed with a Gaussian curve which assures excellent phase and impulse response characteristics, ideally suited to the properties of the musical signal. Three attenuation slope settings (-12 dB/octave, -18 dB/octave, -24 dB/octave) can be chosen independently for the LOW and HIGH frequency range. The GIC (Generalized Immittance Converter) principle used for the filter circuits can simulate the action of an LC filter without the adverse effects of inductance. Circuit constants can be precisely selected, to achieve highly accurate crossover frequency and attenuation slope settings. The music signal in the pass-band is not routed through an amplifier which is highly desirable in terms of signal purity.

The crossover frequency is determined by filter boards which are available as options

and are inserted in rear-panel slots. This allows the shortest possible connection to the filter amplifier, to prevent signal degradation. A wide range of boards for different frequencies are available. The balanced principle used for the input and output stages assures high S/N ratio. All aspects of this product reflect the technological expertise and multi-amplification know-how accumulated by Accuphase over many years. The F-20 is easy to use and provides an effortless entry into a new dimension of audio enjoyment.

**Dedicated Two-Way Dividing Model With Totally Balanced Input and Output Stages** Balanced signal transmission employs two identical signals with opposite phase, which makes it possible to completely cancel out any high-frequency noise or other interference components that may enter the signal path via the wiring or the power supply. This is especially important in multi-amplification systems where longer cable runs and more connections are required.

As shown in Figure 1, the F-20 is a dedicated two-way frequency divider with balanced input and output stages. Balanced lines are especially desirable for high-efficiency horn-loaded drivers, which benefit notably from a noise-free, highly pure signal. A rear-panel switch allows the use of unbalanced lines as well, if desired.

**Gaussian Curve Filter Characteristics Assure Superior Phase Response**

The F-20 adopts filters with Gaussian curve characteristics, which are mostly found in high-precision measurement instruments and

FFT analyzers. Compared to conventional Butterworth type filters, they provide superb impulse and waveform fidelity.

**High-Precision GIC Filter Circuits**

The filter circuits employ the GIC (Generalized Immittance Converter) principle. The low-pass filter is shown in Figure 2 and the high-pass filter in Figure 3. Whereas conventional filters require inductance (L) and capacitance (C), the GIC type filter achieves the same effect using only capacitance (C) and resistance (R).

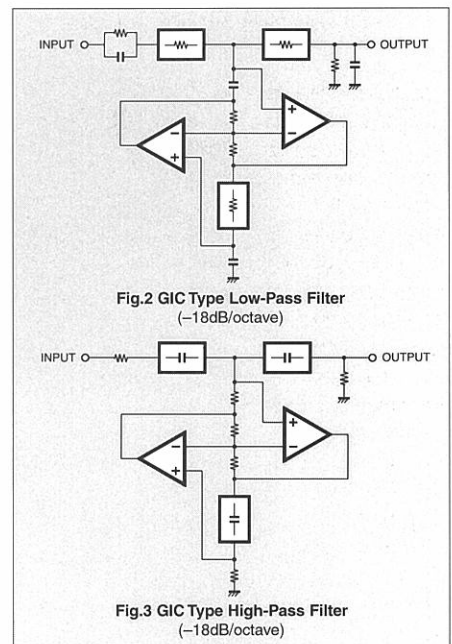

As opposed to conventional feedback-type filters, the GIC filter does not require the signal in the passband to be routed through an amplifier which is highly desirable in terms of signal purity. Circuit constants can be precisely selected, thereby achieving highly accurate crossover frequency and attenuation slope settings.

**Three Selectable Attenuation Slopes**

A front-panel selector allows the user to choose between three different slope settings: -12 dB/octave, -18 dB/octave, and -24 dB/octave. The higher the figure, the steeper the cutoff curve, i.e. the more thoroughly the suppression of other frequencies. Separate selectors are provided for the HIGH and LOW channels, allowing individual adjustment.

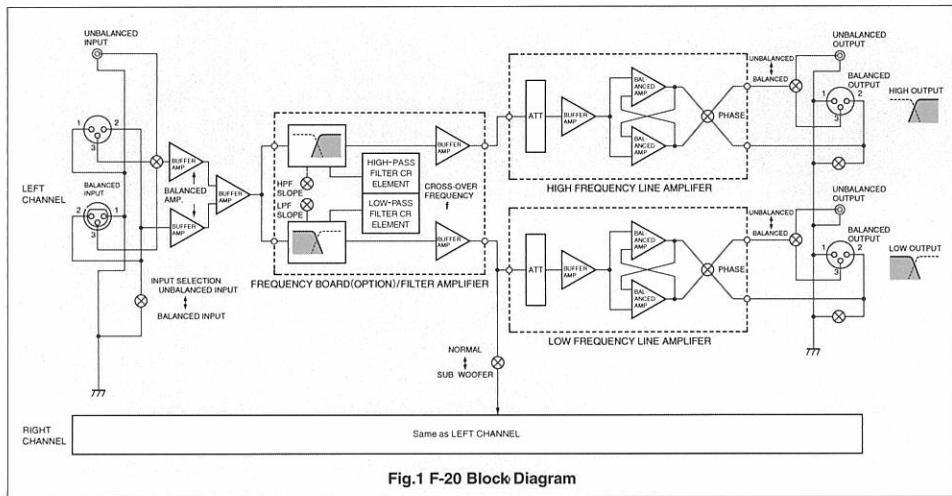
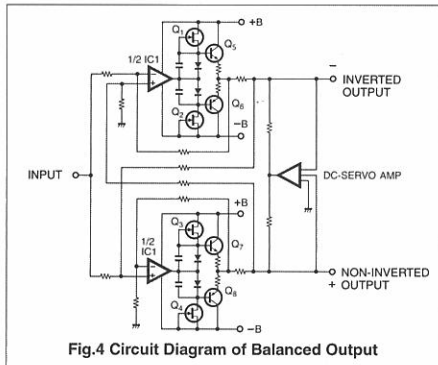

Fig. 1 F-20 Block Diagram

## Modular Balanced Output Stage

Figure 4 shows the balanced output circuitry of the line amplifier for each frequency band. Two amplifiers are used whose outputs are connected in a cross-feedback arrangement. This sends symmetrical positive and negative signals with low impedance to the output. This circuit topology results in an ideal configuration where the positive and negative signals are isolated from ground. Even if one side of the output is grounded, both amplifiers continue to operate and the output voltage does not change.



For unbalanced connections, it therefore suffices to simply ground one side of the output. Sound quality does not change either in

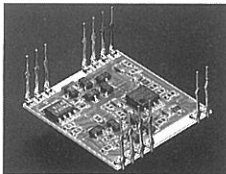

Balanced Output Circuit Module

balanced or unbalanced mode. To further enhance operating stability, the entire circuitry is contained in a module and mounted on an alumina ceramic substrate with superior heat transmission characteristics.

## Phase Reversal Switch Without Sound Quality Degradation

Separate phase reversal switches are provided for the HIGH and LOW channels. In multi-amplification systems, it is necessary to match the phase of the speaker units, to assure uniform energy distribution in the vicinity of the crossover frequency. This may require reversing of amplifier or speaker phase. The selectors of the F-20 make this task very simple. Because the phase is switched simply by reversing the connection of the balanced output amplifier, there are no side effects or sound quality degradation.

## Subwoofer Ready

In the extreme low-frequency range, where sound source localization is not critical, the right and left signals can be combined and reproduced by a single subwoofer. This allows use of a large woofer also in listening rooms where space is limited. The F-20 makes it possible to provide high-quality subwoofer output by using a rear-panel switch for the LOW channel output.

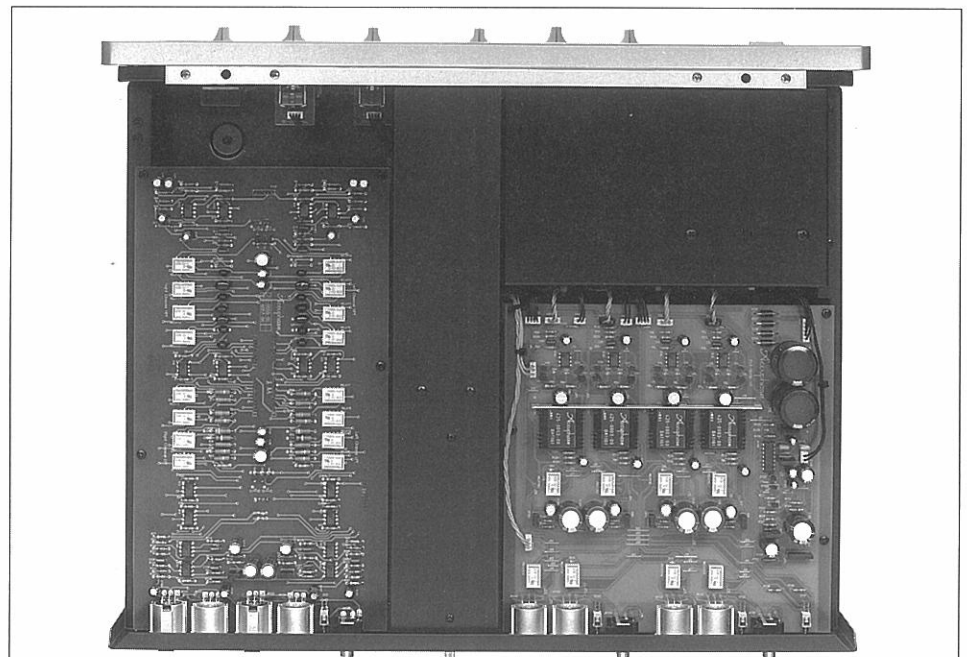

### ■ Clean internal layout

On the top plate side, the line amplifier and filter amplifier assemblies can be seen, and on the bottom plate side the power transformer. The slot for optional frequency boards is located in the center of the rear panel.

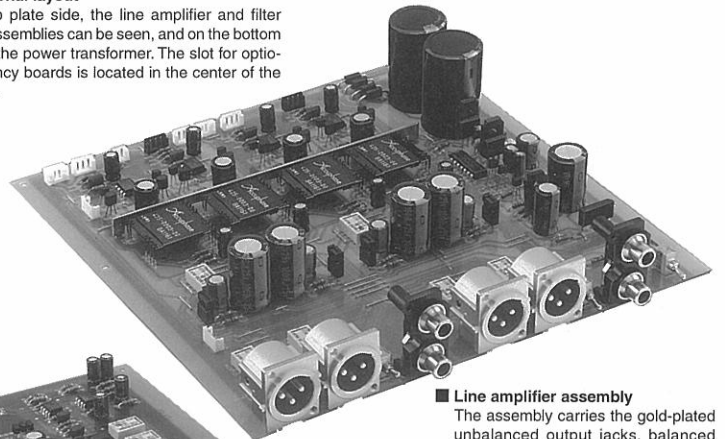

### ■ Line amplifier assembly

The assembly carries the gold-plated unbalanced output jacks, balanced XLR connectors linked directly to the balanced output amplifier module, and line amplifiers for the low and high frequency range.

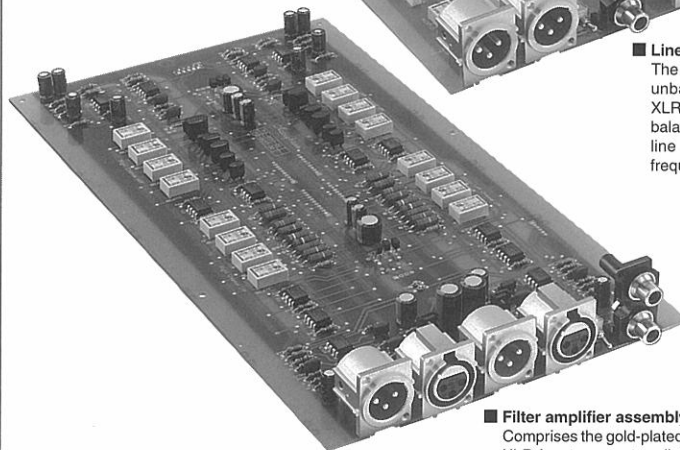

### ■ Filter amplifier assembly

Comprises the gold-plated unbalanced input jacks, balanced XLR input connectors linked directly to the input circuitry, high-precision GIC filters, and filter amplifier using Gaussian curve characteristics.

## Ultra-Precise Level Controls

The output amplifier unit incorporates high-precision attenuators which allow independent level adjustments for each channel. Adjustment is possible in 0.5-dB steps from 0 to -8 dB and 1-dB steps from -8 to -20 dB. A "∞" position is also provided to turn that channel off. This arrangement allows precise level matching.

## Dedicated Model for Two-Way Drive of JBL M9500, Project K2 S9500, and Project K2 S7500

A special version of the F-20, called F-20M, is available, designed specifically to implement two-way drive of the JBL speakers M9500, Project K2 S9500, and Project K2 S7500. The internal dedicated filter amp of the F-20M, in conjunction with the dedicated frequency board FB-650M, achieves characteristics which are identical to the LC network in the speaker. Externally, the F-20M looks like the F-20, but the slope selector is fixed to -18 dB/octave.

## Optional Frequency Boards

Changes in crossover frequency are accomplished by changing the frequency board inserted in a dedicated slot on the rear of the unit. This design allows straight and extremely short signal paths, which is desirable in the interest of sonic purity. PPS (PolyPropylene-Styrol) capacitors and high-precision carbon film resistors are used in all critical areas to prevent sound coloration. Installation and removal of frequency boards is easy and quick, thanks to a reliable connector design. 21 types of standard frequency boards (same as for model F-25) are available, ranging from 70 to 12,500 Hz. The F-20 does not come with a pre-installed board, allowing the user to make an individual choice.

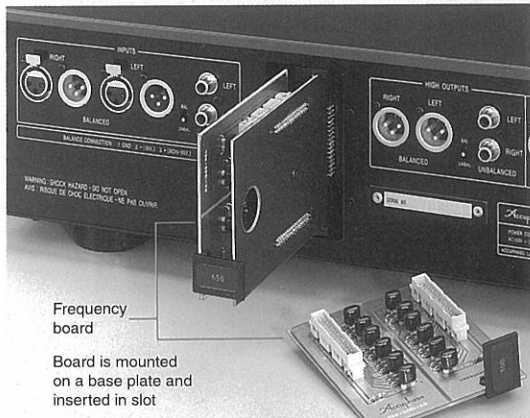

Frequency board

Board is mounted on a base plate and inserted in slot

## Frequency Board Types

Crossover frequency	Model number	Crossover frequency	Model number
70Hz	FB-70	1,000Hz	FB-1000
100Hz	FB-100	1,200Hz	FB-1200
130Hz	FB-130	1,800Hz	FB-1800
180Hz	FB-180	2,500Hz	FB-2500
250Hz	FB-250	3,500Hz	FB-3500
290Hz	FB-290	5,000Hz	FB-5000
300Hz	FB-300	7,000Hz	FB-7000
350Hz	FB-350	8,000Hz	FB-8000
500Hz	FB-500	10,000Hz	FB-10000
650Hz	FB-650	12,500Hz	FB-12500
800Hz	FB-800		

\*Same as for F-25

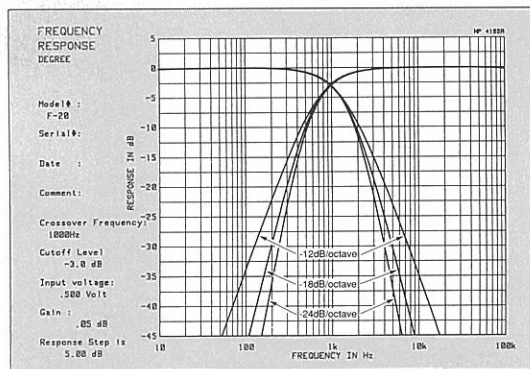

Frequency characteristics: crossover frequency 1 kHz (3 switchable slopes)

## Front panel

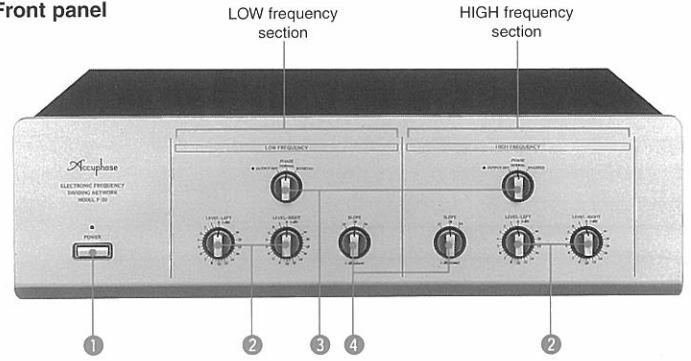

## Rear panel

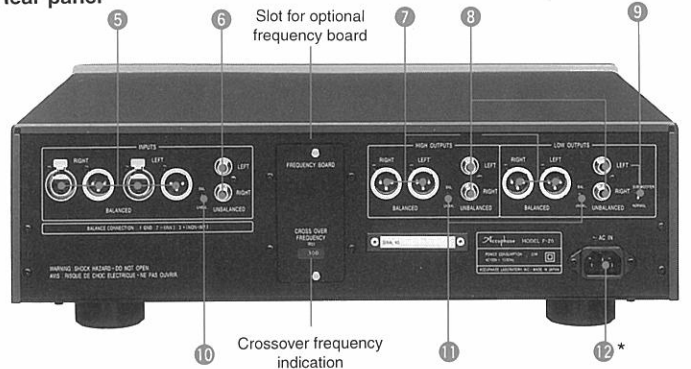

- 1 Power switch
- 2 Left/right channel level controls
- 3 Output off/phase selector switch  
OUTPUT OFF PHASE NORMAL  
PHASE INVERTED
- 4 Slope selector  
-12dB/octave -18dB/octave -24dB/octave
- 5 Balanced input connectors (male/female)
- 6 Unbalanced input connectors
- 7 Balanced output connectors
- 8 Unbalanced output connectors
- 9 Subwoofer selector  
NORMAL/SUBWOOFER
- 10 Input type selector  
BALANCED/UNBALANCED
- 11 Output type selector  
BALANCED/UNBALANCED
- 12\* AC power connector  
(For supplied power cord)\*

## Remarks

\*The shape of the plug of the supplied power cord depend on the voltage rating and destination country.

## F-20 Guaranteed Specifications

(measured according to EIA standard RS-490)

- **Maximum input level**  
(THD 0.01% or less, 20 - 20,000 Hz)  
BALANCED: 5.0 V  
UNBALANCED: 5.0 V
- **Total Harmonic Distortion**  
(20 - 20,000 Hz, output level 2.0 V)  
0.003%
- **Frequency response**  
(single channel, equivalent bandwidth)  
20 - 20,000 Hz +0 -0.2 dB  
0.5 - 300,000 Hz +0 -3.0 dB
- **Gain**  
0 dB
- **Crossover frequency**  
Selectable by plug-in frequency board  
Standard frequencies: 21
- **Crossover characteristics**  
-3.0 dB  $\pm$ 5%
- **Attenuation slope**  
-12 dB/octave, -18 dB/octave, -24 dB/octave switchable
- **Input impedance**  
BALANCED: 40 kohms, UNBALANCED: 20 kohms
- **Output impedance**  
BALANCED: 50 ohms, UNBALANCED: 50 ohms
- **Minimum load impedance**  
BALANCED: 600 ohms, UNBALANCED: 600 ohms
- **S/N ratio (output level 0.5 V, IHF-A weighed)**  
100 dB
- **Level adjustment**  
0 to -8 dB in 0.5-dB steps  
-8 to -20 dB in 1-dB steps,  $-\infty$
- **Power requirements**  
100V, 120V, 220V, 230V, 240V (Voltage as indicated on rear panel), 50/60 Hz AC  
20 watts
- **Power consumption**  
20 watts
- **Maximum dimensions**  
Width 475 mm (18-11/16")  $\times$  Height 150 mm (5-7/8")  $\times$  Depth 395 mm (15-9/16")  
10.4 kg (22.9 lbs) net  
15.5 kg (34 lbs) in shipping carton
- **Weight**

\* Specifications and design subject to change without notice for improvements.

**Accuphase**  
ACCUPHASE LABORATORY INC.

PRINTED IN JAPAN C985Y 851-0156-00(AD1)